

ACME-SHOREY

PRECAST CONCRETE PRODUCTS

WWW.ACME-SHOREY.COM

PHONE (508) 548-9607

FAX (508) 548-1664

CARVER, MA

334 TREMONT STREET

HARWICH, MA

36 GREAT WESTERN ROAD

NOTES:

1.) OPTIONAL : FRAME & COVER

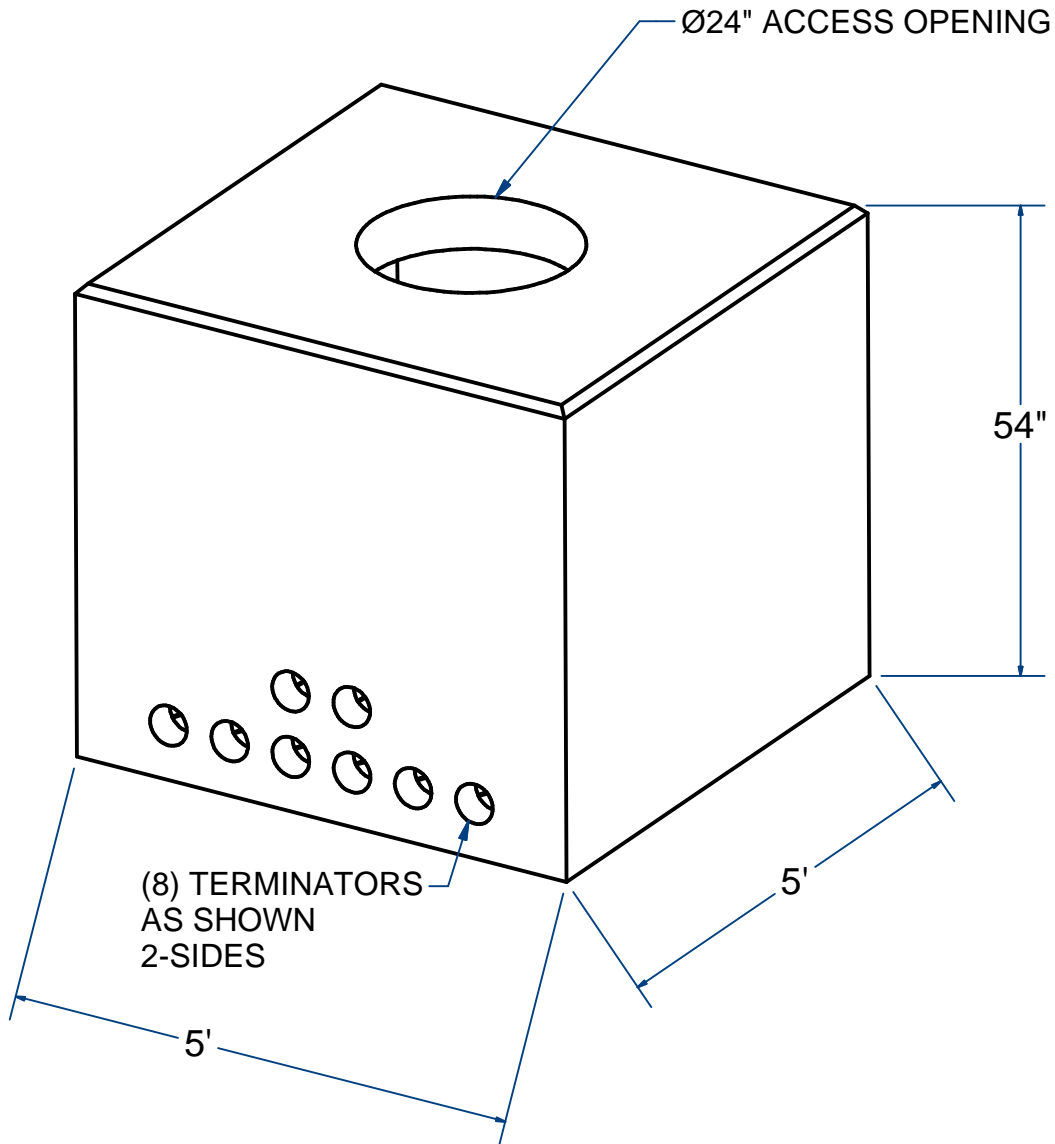

METER PIT 5' X 5'

H20

PROVINCETOWN/STANDARD SPEC

ITEM# MP5X52

Wt. 7,000 Lbs

21-2.1

Sht 1 of 2

ACME-SHOREY

PRECAST CONCRETE PRODUCTS

NOTES:

1.) OPTIONAL : FRAME & COVER

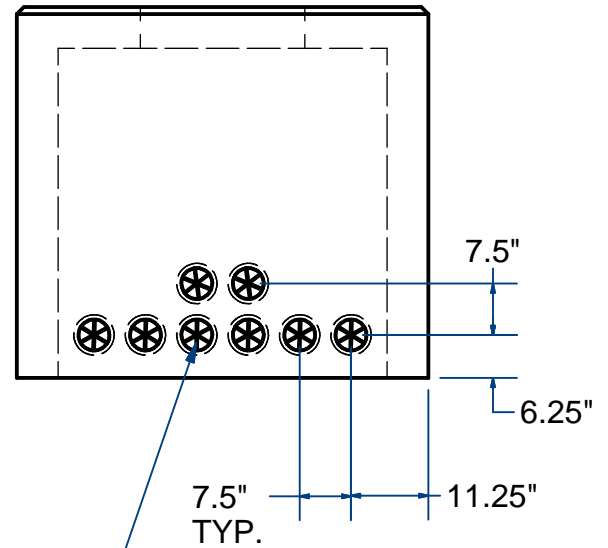
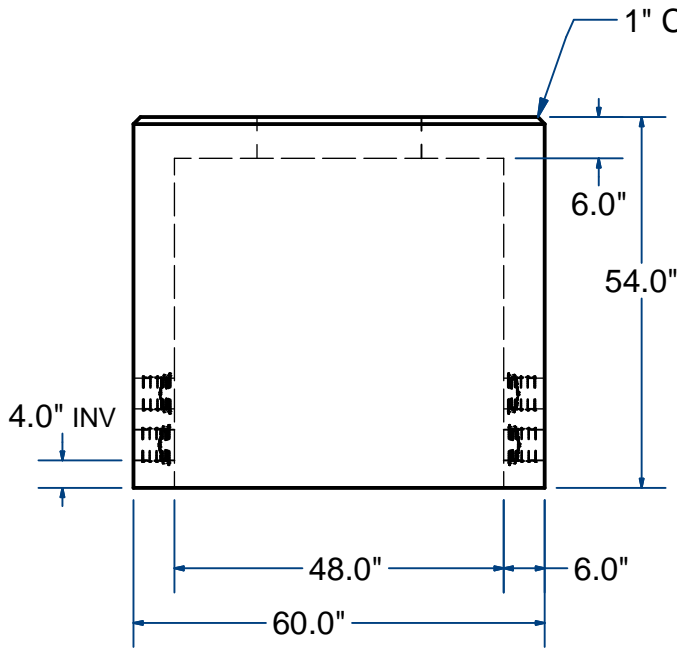
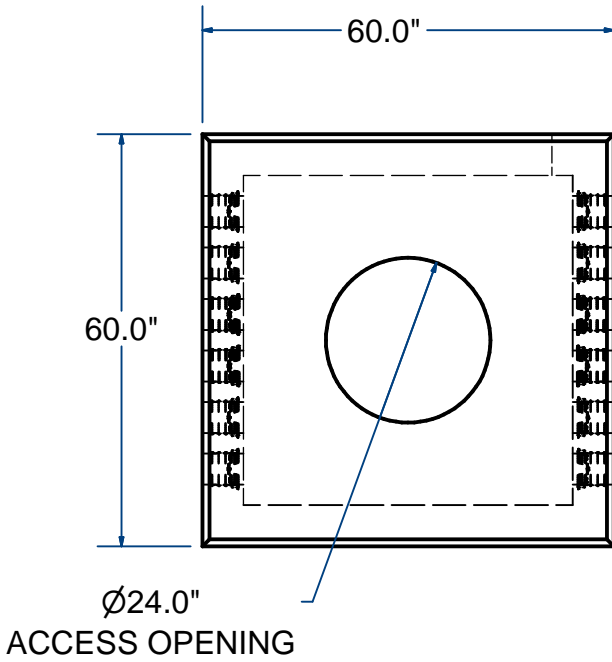

Ø4" UNI-DUCT TERMINATORS
(8) PER SIDE (ON 2-SIDES)
THRU

NAME: METER PIT 5' X 5'
(PROVINCETOWN SPEC / STANDARD SPEC)

H-20

ITEM# MP5X52

Concrete Minimum Strength: 5,000 p.s.i. at 28 days
Steel Reinforcement: ASTM A615, Grade 60
Design Loading: standard units - AASHTO - H20

WEIGHT 7,000

Lbs

H

DATE: 12-13-24

Ch 21 Pg 2.1 Sht 2 of 2