

# ACME-SHOREY

PRECAST CONCRETE PRODUCTS

334 TREMONT STREET

CARVER, MA 02330

PHONE (508) 548-9607 FAX (508) 548-1664

FALMOUTH

THOMAS B. LANDERS ROAD

HARWICH

36 GREAT WESTERN ROAD

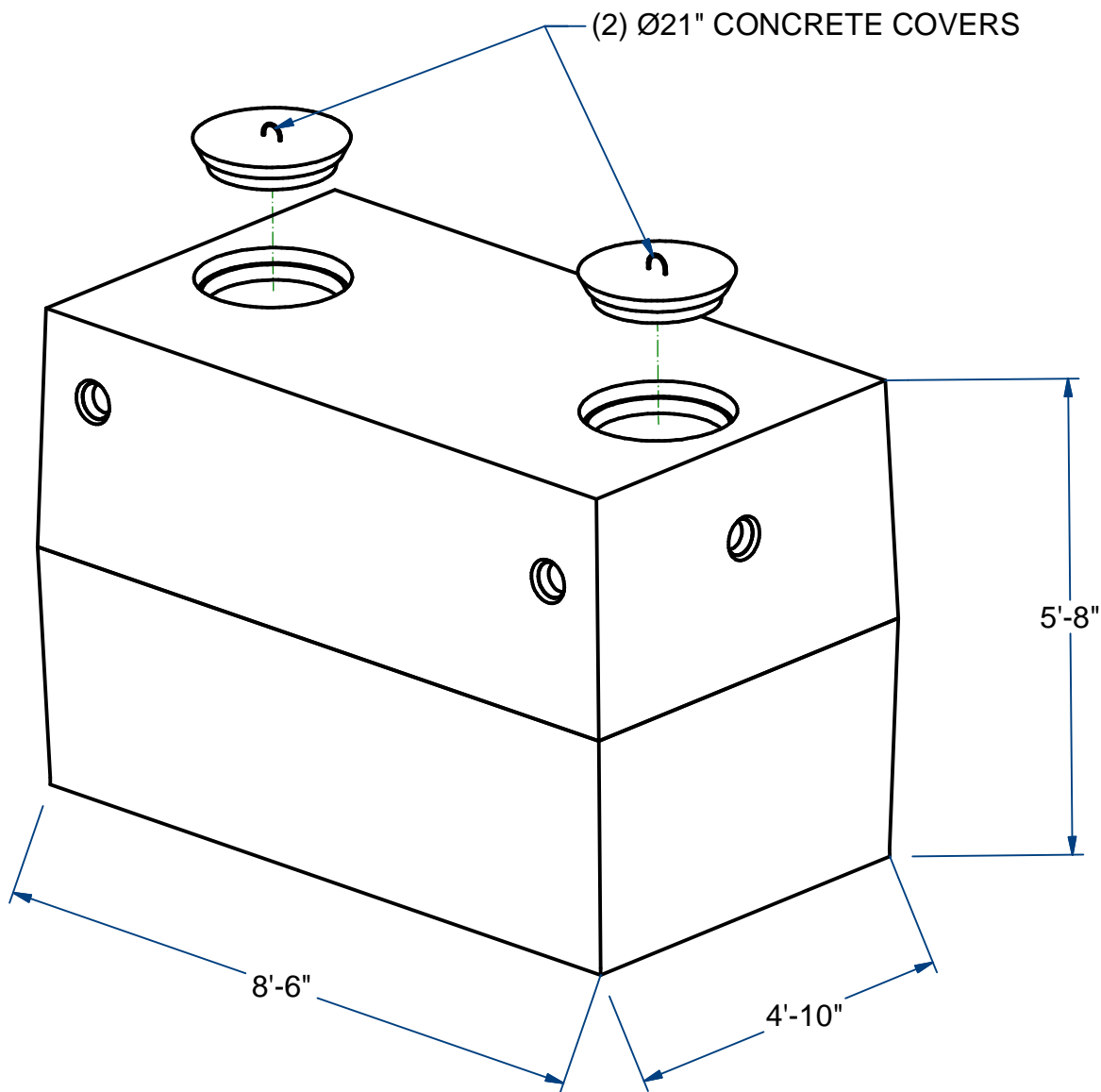

## SEPTIC TANK

H10

1000 Gallon

ITEM# ST 10

Wt. 8,300 Lbs

1 -1

Sht 1 of 2

# ACME-SHOREY

PRECAST CONCRETE PRODUCTS

NOTES:

- 1.) SEAM SEALED WITH FLEXIBLE BUTYL RUBBER SEALANT.

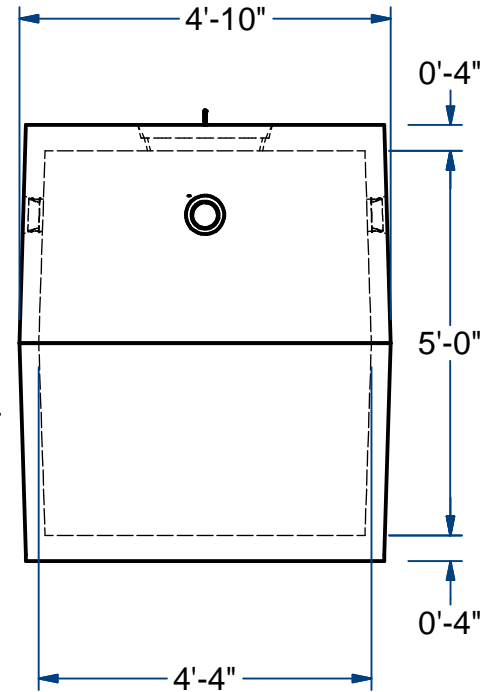
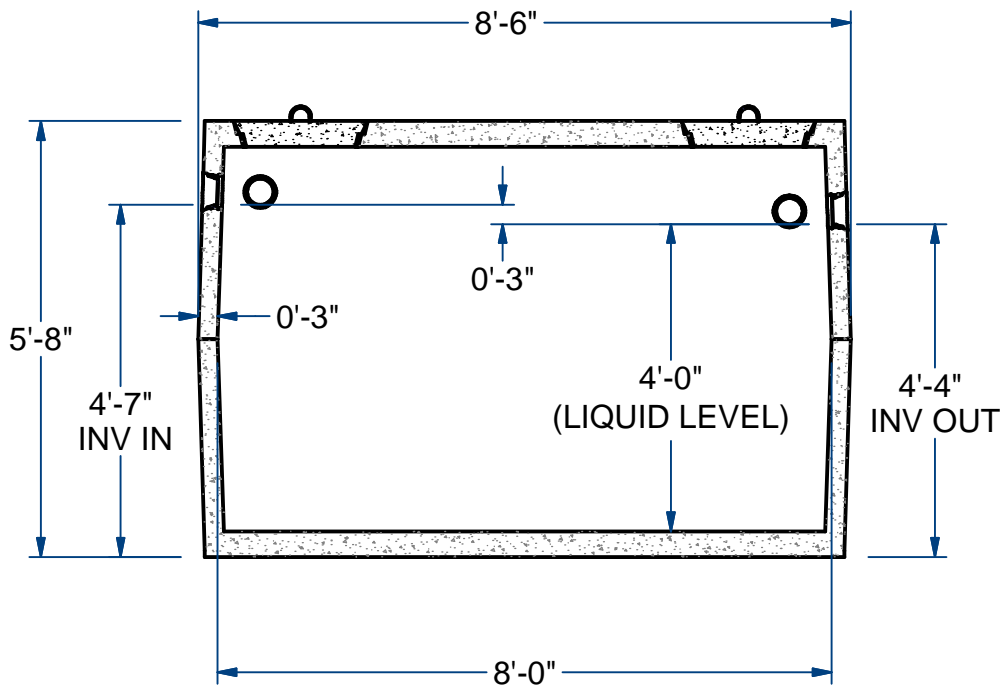
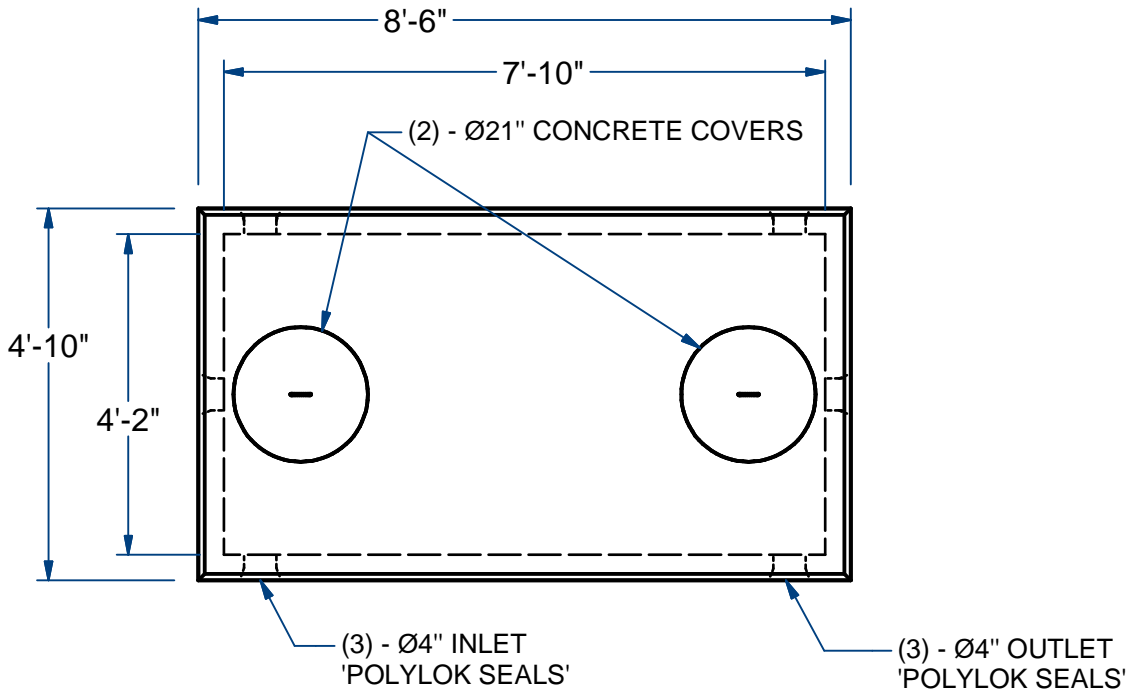

**NAME: SEPTIC TANK, 1000 Gallon**

**H-10**

**ITEM# ST10**

Concrete Minimum Strength: 4,000 p.s.i. at 28 days  
 Steel Reinforcement: ASTM A615, Grade 60  
 Design Loading: standard units - AASHTO - H10

TOP 3,900 Lbs  
 BOTTOM 4,400 Lbs

AS

DATE: 3-29-2017

Ch 1

Pg 1

Sht 2 of 2