

ACME-SHOREY

PRECAST CONCRETE PRODUCTS

WWW.ACMESHOREY.COM

PHONE (508) 548-9607

FAX (508) 548-1664

CARVER, MA

334 TREMONT STREET

HARWICH, MA

36 GREAT WESTERN ROAD

NOTES:

- 1.) SEAM SEALED WITH FLEXIBLE BUTYL RUBBER SEALANT.

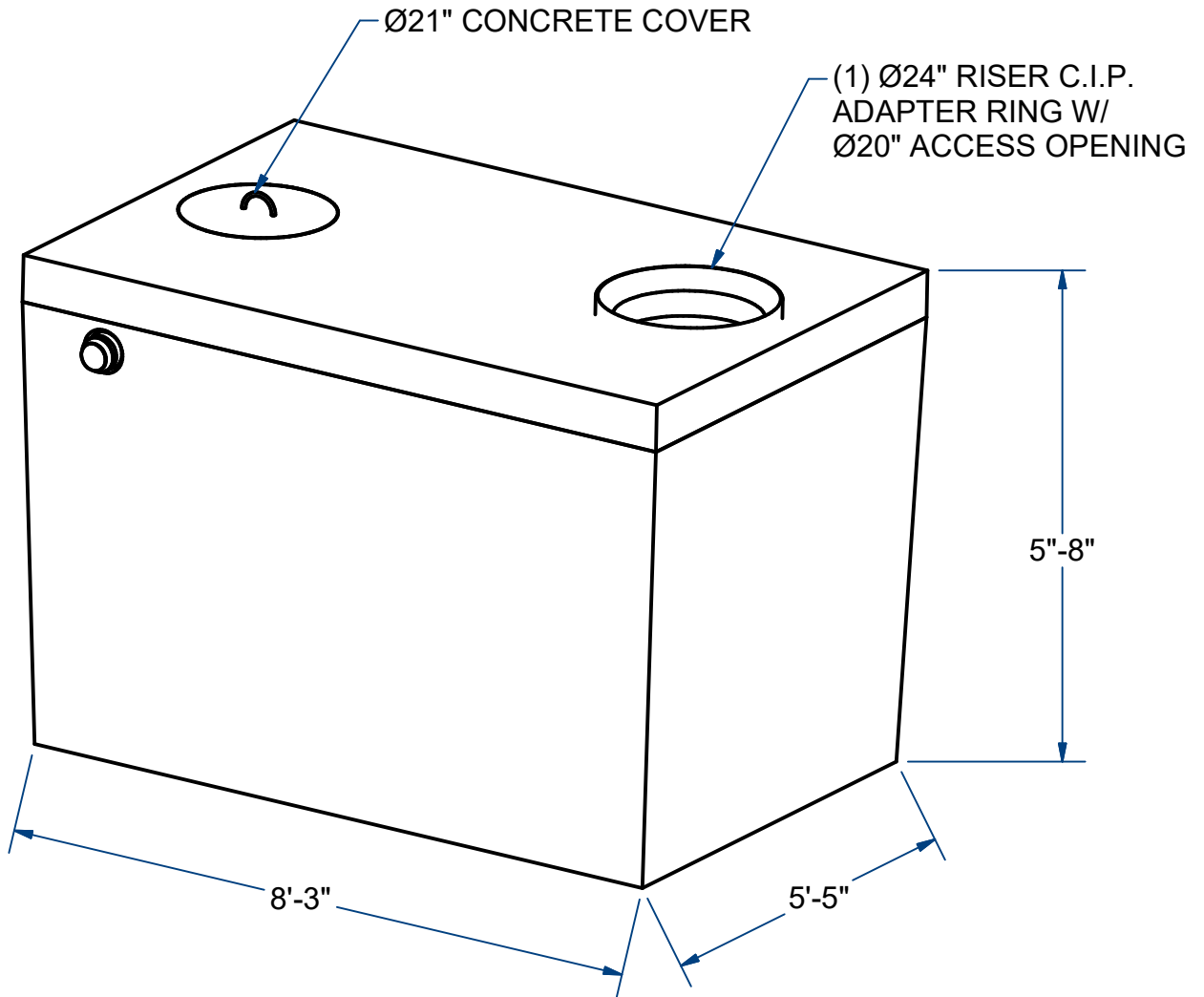

ADVANTEX DISCHARGE TANK, MONO

FOR PROCESS INFO
PLEASE CONTACT:

AdvanTex[®]
Treatment Systems
ORENCO SYSTEMS
(800) 348-9843
info@orencosystems.com
www.orencosystems.com

H10

1000 Gallon

ITEM# AX20D-10M

Wt. 8,500 Lbs

7 -1.4

Sht 1 of 2

ACME-SHOREY

PRECAST CONCRETE PRODUCTS

NOTES:

- 1.) SEAM SEALED WITH FLEXIBLE BUTYL RUBBER SEALANT.

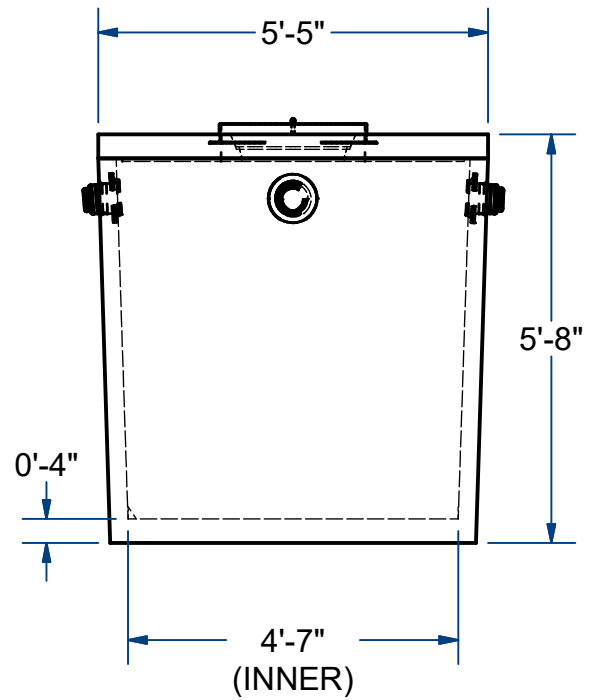
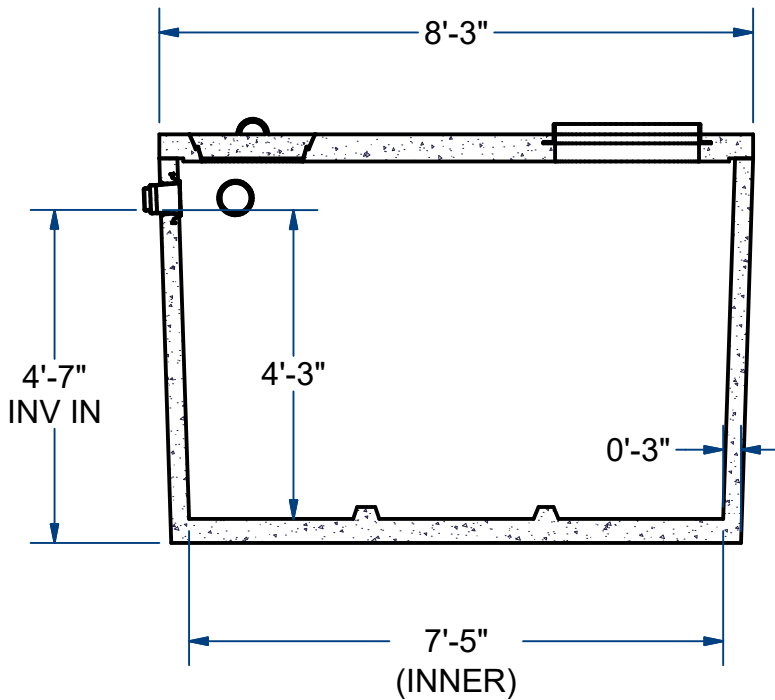
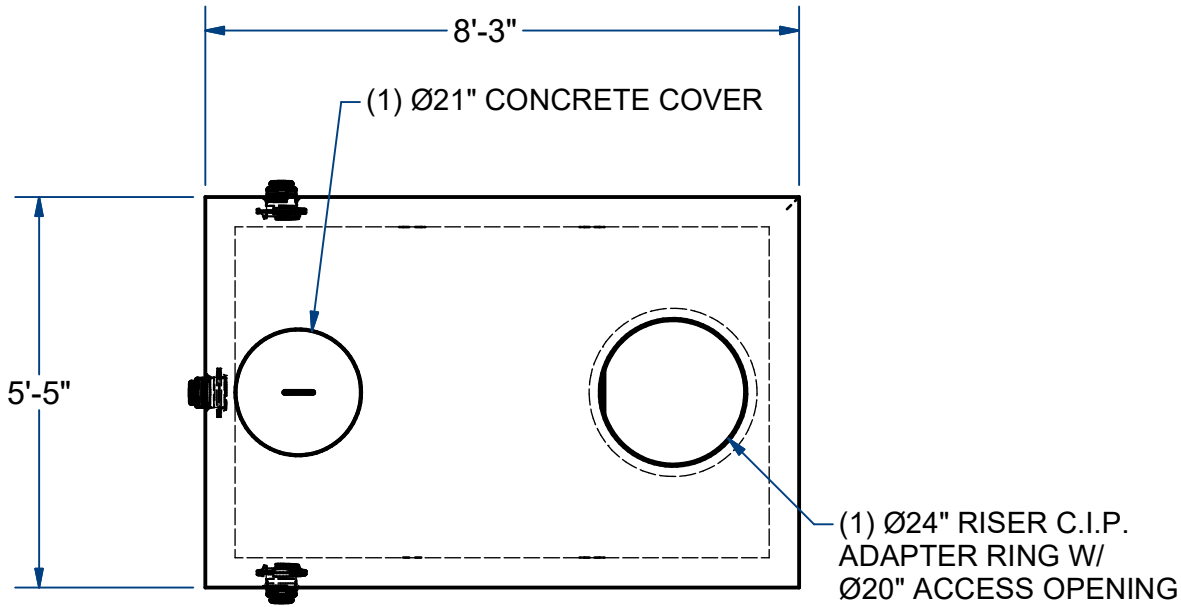

NAME: ADVANTEX DISCHARGE TANK, Mono1000Gallon

H-10

ITEM# AX20D-10M

Concrete Minimum Strength: 4,000 p.s.i. at 28 days
 Steel Reinforcement: ASTM A615, Grade 60
 Design Loading: standard units - AASHTO - H10

TOP 2,500 Lbs
 BOTTOM 6,000 Lbs

H

DATE: 11-4-25

Ch 7 Pg 1.4 Sht 2 of 2