

ACME-SHOREY

PRECAST CONCRETE PRODUCTS

NOTES:

- 1.) LIFTING HOOKS TIED TO REBAR CAGE.
- 2.) LIFTING HOOKS NEED TO BE MIN 8" IN FROM OUTER EDGES TO ALLOW CHAMBER TO SIT ON TOP.
- 3.) REBAR CAGE TO BE #3 DEFORMED REBAR, 8" ON CENTER IN BOTH DIRECTIONS.

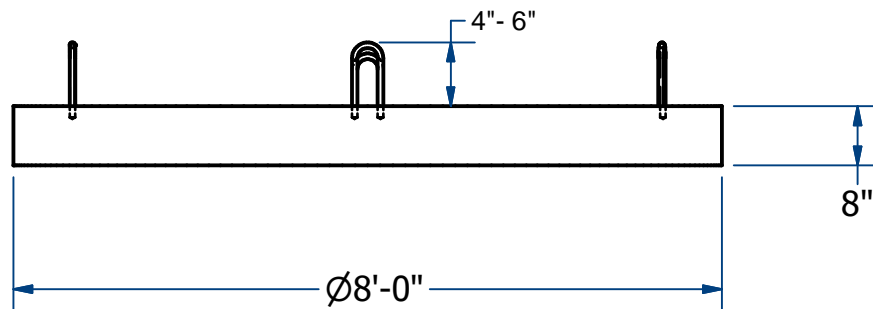
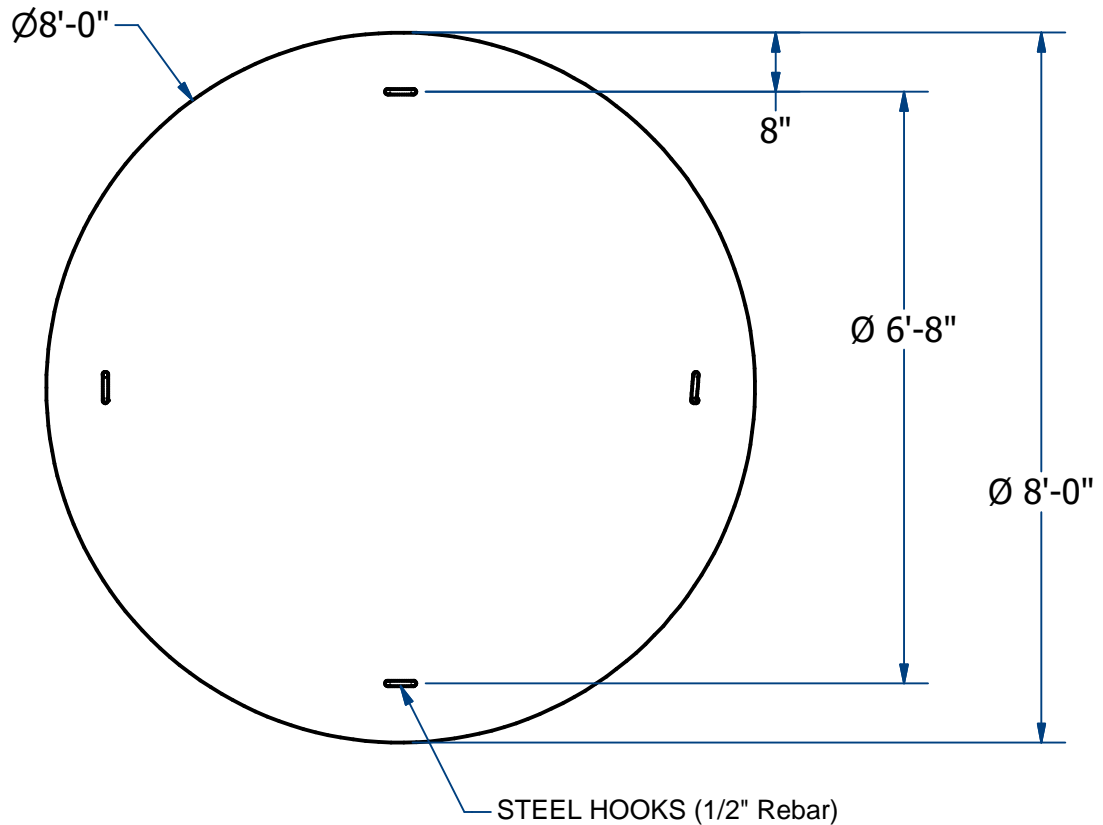

NAME: BASE ,LEACHING 8'DIA

H-20

ITEM# B8

Concrete Minimum Strength: 5,000 p.s.i. at 28 days
 Steel Reinforcement: ASTM A615, Grade 60
 Design Loading: standard units - AASHTO - H20

WEIGHT 5,020 Lbs

AS

DATE: 8-11-2018

Ch 12 Pg 9.3 Sht 1