

ACME-SHOREY

PRECAST CONCRETE PRODUCTS

WWW.ACMESHOREY.COM

PHONE (508) 548-9607

FAX (508) 548-1664

CARVER, MA

334 TREMONT STREET

HARWICH, MA

36 GREAT WESTERN ROAD

NOTES:

1.) EACH UNIT HAS STEEL REINFORCEMENT.

2.) (2) $\text{Ø}5/8$ " X 18" Lg ANCHOR PINS PER BUMPER STOP.

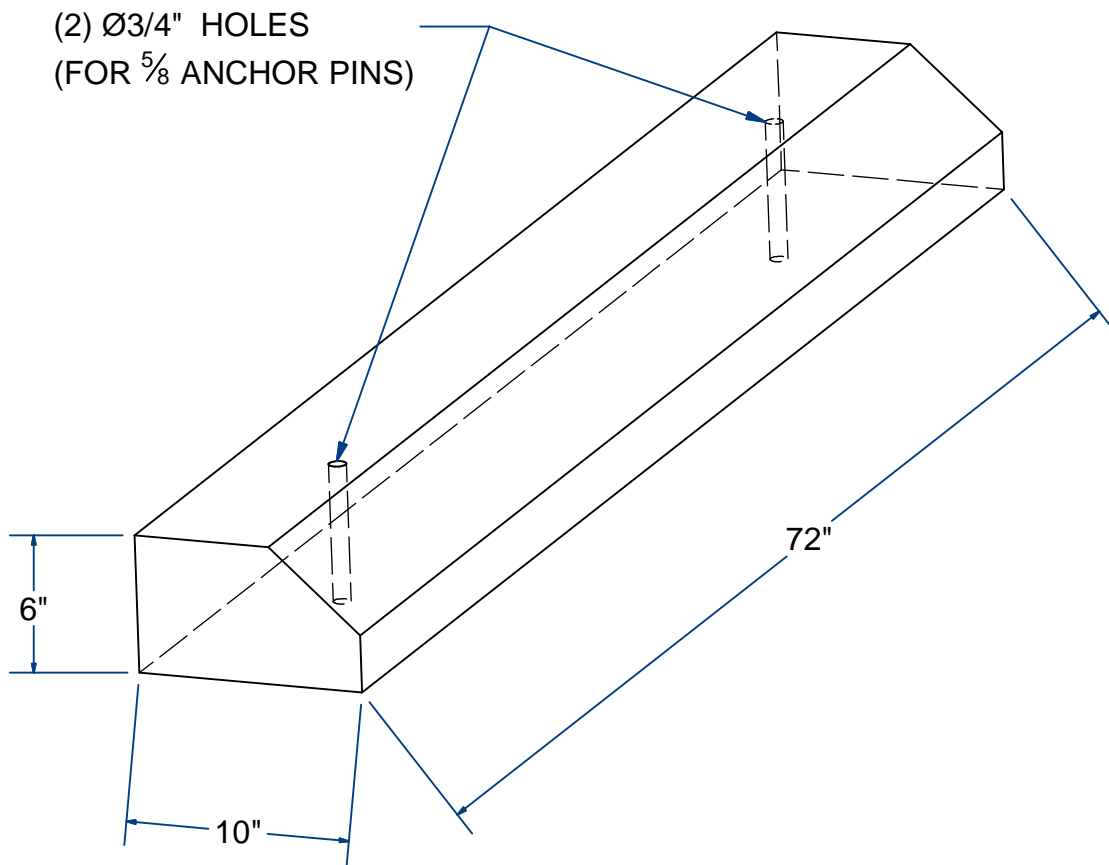

BUMPER STOP 6" Ht

72" LGTH

6" X 10"

ITEM# **BS6**

Wt. 332 Lbs

19-4.1

Sht 1 of 2

ACME-SHOREY

PRECAST CONCRETE PRODUCTS

NOTES:

- 1.) EACH UNIT HAS STEEL REINFORCEMENT.
- 2.) (2) $\text{Ø}^{5/8}$ " X 18" Lg ANCHOR PINS PER BUMPER STOP.

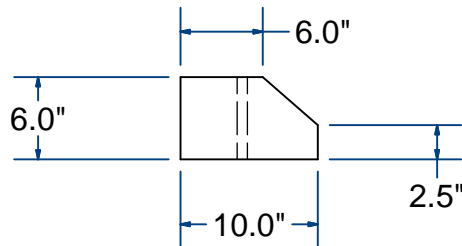
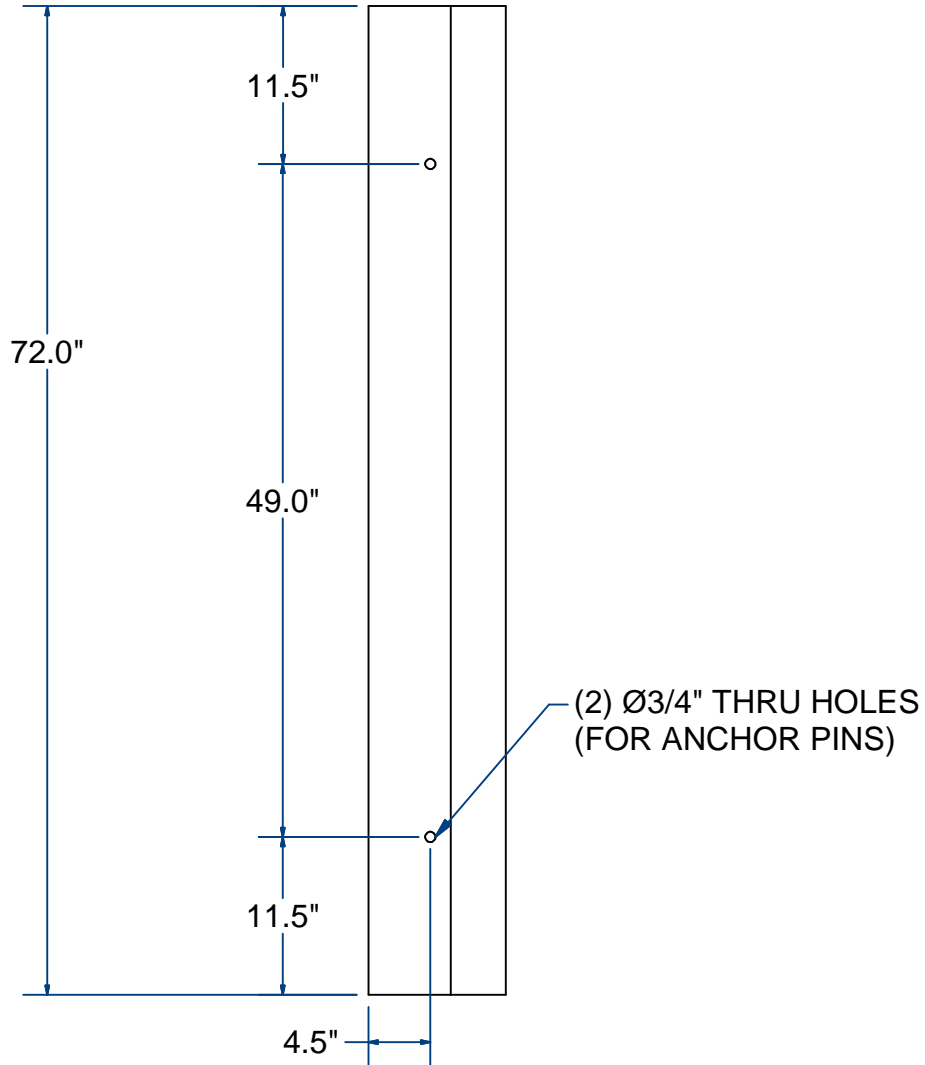

NAME: BUMPER STOP X 6' Lgth

H-20

ITEM# BS6

Steel Reinforcement: ASTM A615, Grade 60

WEIGHT 332 Lbs

CH

DATE: 11-10-20