

NOTES:

- 1.) OPTIONAL- Ø21" COVER
- 2.) CAPACITY 25 GALLONS AT INV.

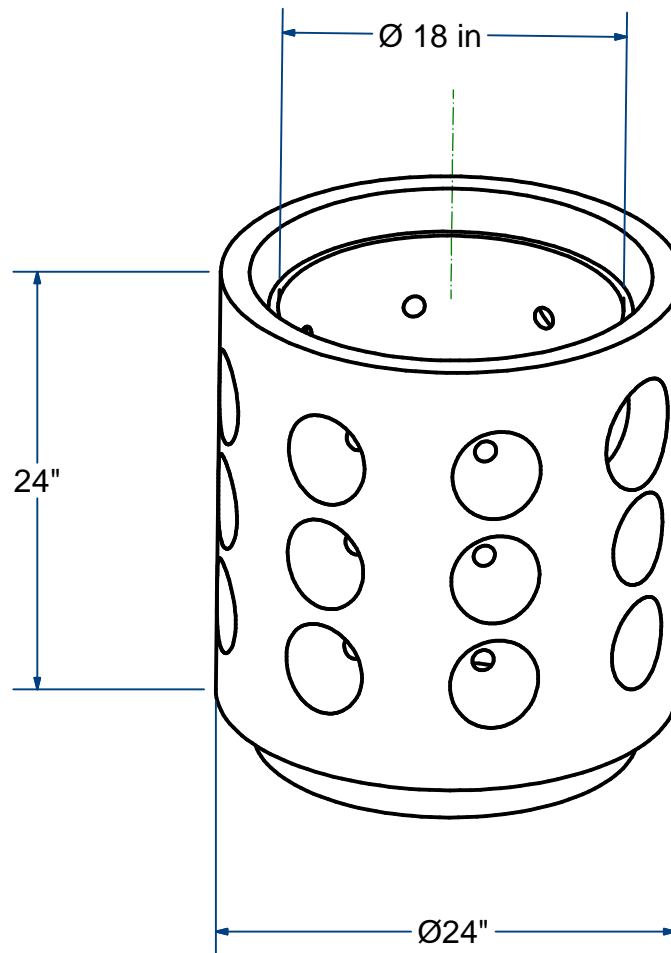

**DRYWELL 24" OD**

24" Ht

H10

# ACME-SHOREY

PRECAST CONCRETE PRODUCTS

**NOTES:**

- 1.) CAPACITY 25 GALLONS AT INV.
- 2.) OPTIONAL ITEMS;
  - A.) Ø21" CONCRETE COVER.
  - B.) RC183 STEEL RING & COVER.
  - C.) RG185 STEEL RING & GRATE.

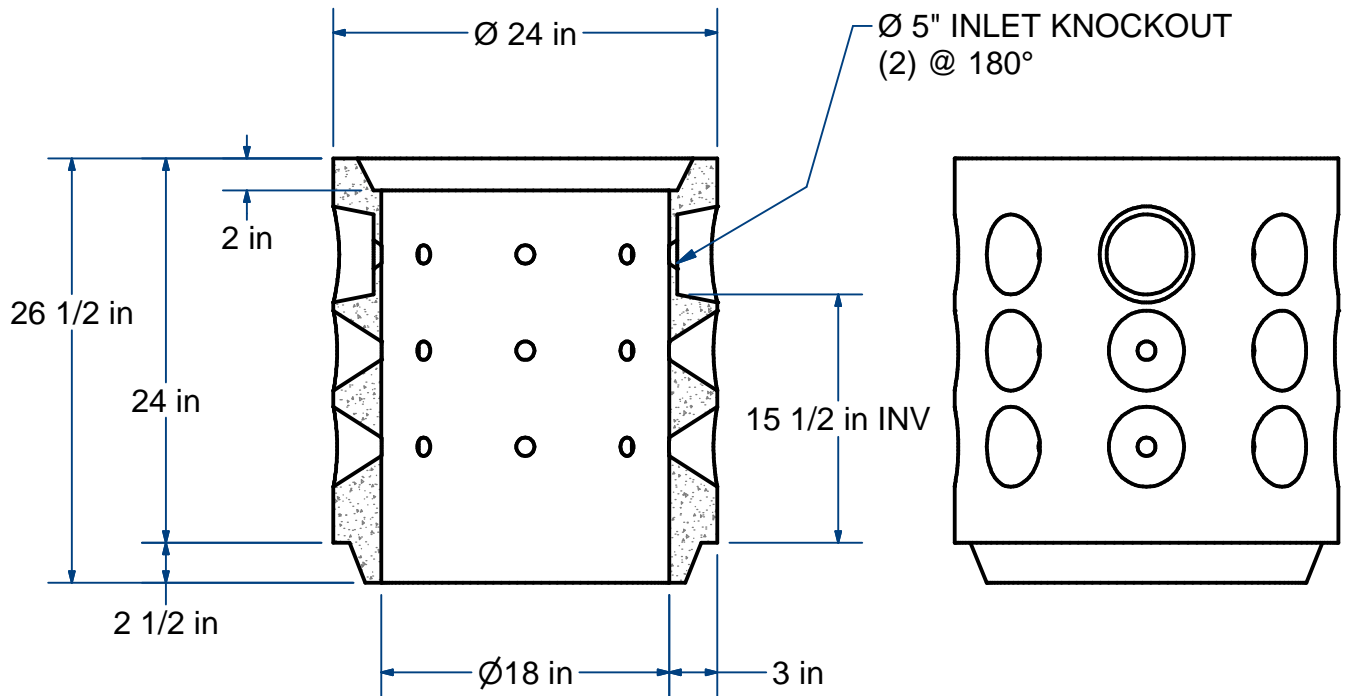
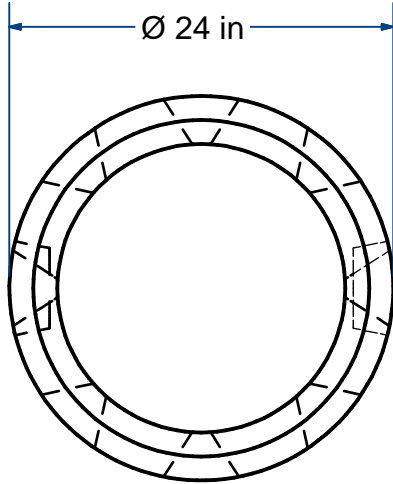

**NAME: DRYWELL 24"OD X 24" Ht**

**H-10**

**ITEM# DW24**

Concrete Minimum Strength: 4,000 p.s.i. at 28 days  
 Steel Reinforcement: ASTM A615, Grade 60  
 Design Loading: standard units - AASHTO - H10

**WEIGHT 370**

**Lbs**

**H**

**DATE: 11-5-2020**