

ACME-SHOREY

PRECAST CONCRETE PRODUCTS

WWW.ACMESHOREY.COM

PHONE (508) 548-9607

FAX (508) 548-1664

CARVER, MA
334 TREMONT STREET

HARWICH, MA
36 GREAT WESTERN ROAD

- NOTES:
1.) INCLUDES C21 CONCRETE COVER.
2.) CAPACITY 65 GALLONS TO INV.

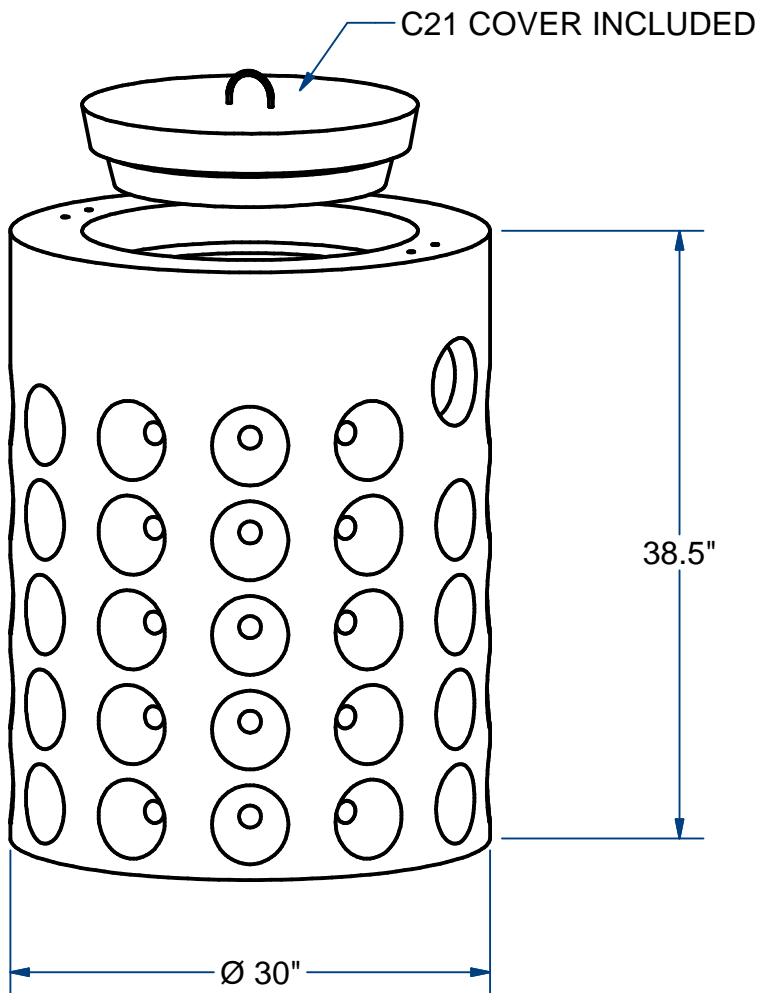

DRYWELL 30" OD

38.5 Ht

H20

ITEM# DW382

Wt. 800

Lbs

19-1.2

Sht 1 of 2

ACME-SHOREY

PRECAST CONCRETE PRODUCTS

NOTES:

- 1.) INCLUDES C21 CONCRETE COVER.
- 2.) CAPACITY 65 GALLONS TO INV.

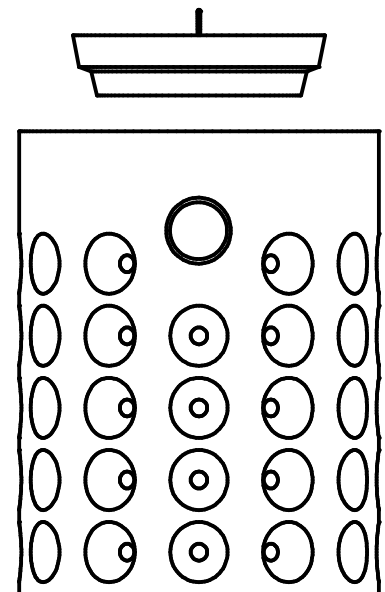
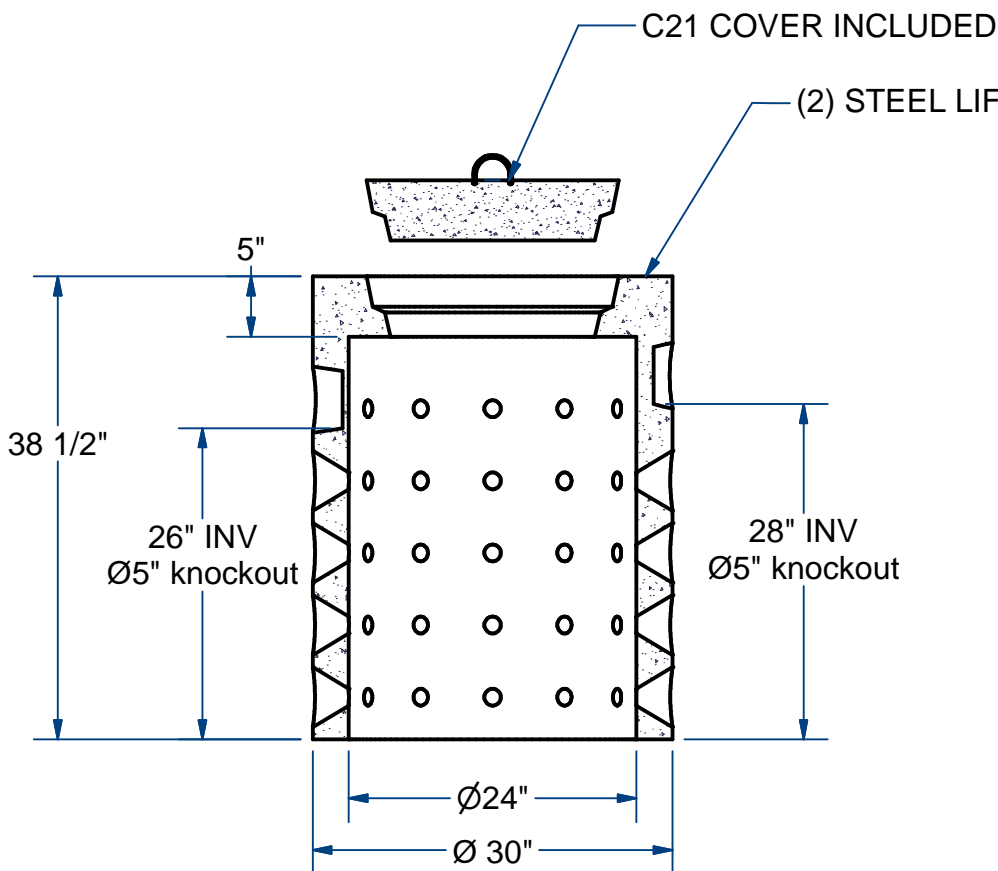
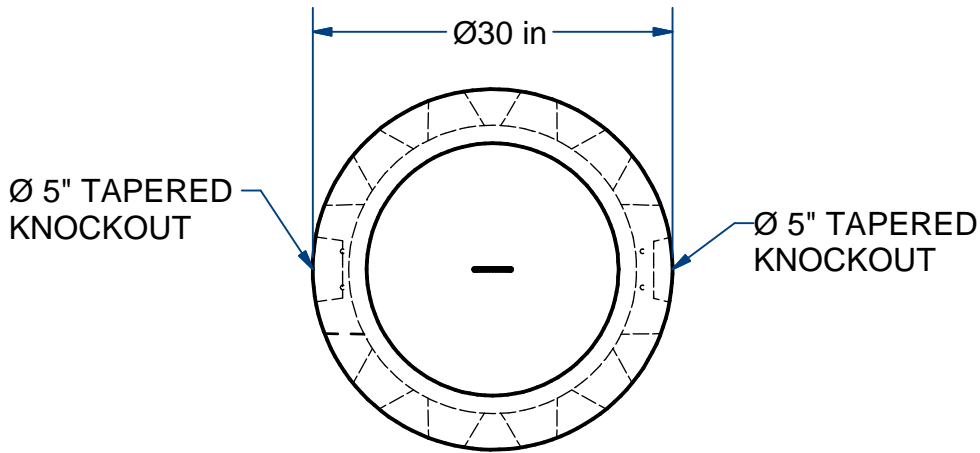

NAME: DRYWELL, 30"OD X 38" Ht

H-20

ITEM# DW382

Concrete Minimum Strength: 5,000 p.s.i. at 28 days
 Steel Reinforcement: ASTM A615, Grade 60
 Design Loading: standard units - AASHTO - H20

WEIGHT 800 Lbs

C

DATE: 11-6-2020