

ACME-SHOREY

PRECAST CONCRETE PRODUCTS

WWW.ACMESHOREY.COM

PHONE (508) 548-9607

FAX (508) 548-1664

CARVER, MA

334 TREMONT STREET

HARWICH, MA

36 GREAT WESTERN ROAD

NOTES:

- 1.) $\varnothing 4$ " CONCRETE HUB & BELL CONNECTORS ALLOW FOR P.V.C. PIPE AND ALSO FOR JOINING FLOW DIFFUSOR TO FLOW DIFFUSOR.
- 2.) CAPACITY TO INV = 100 Gallons.
CAPACITY TO TOP INSIDE = 150 Gallons

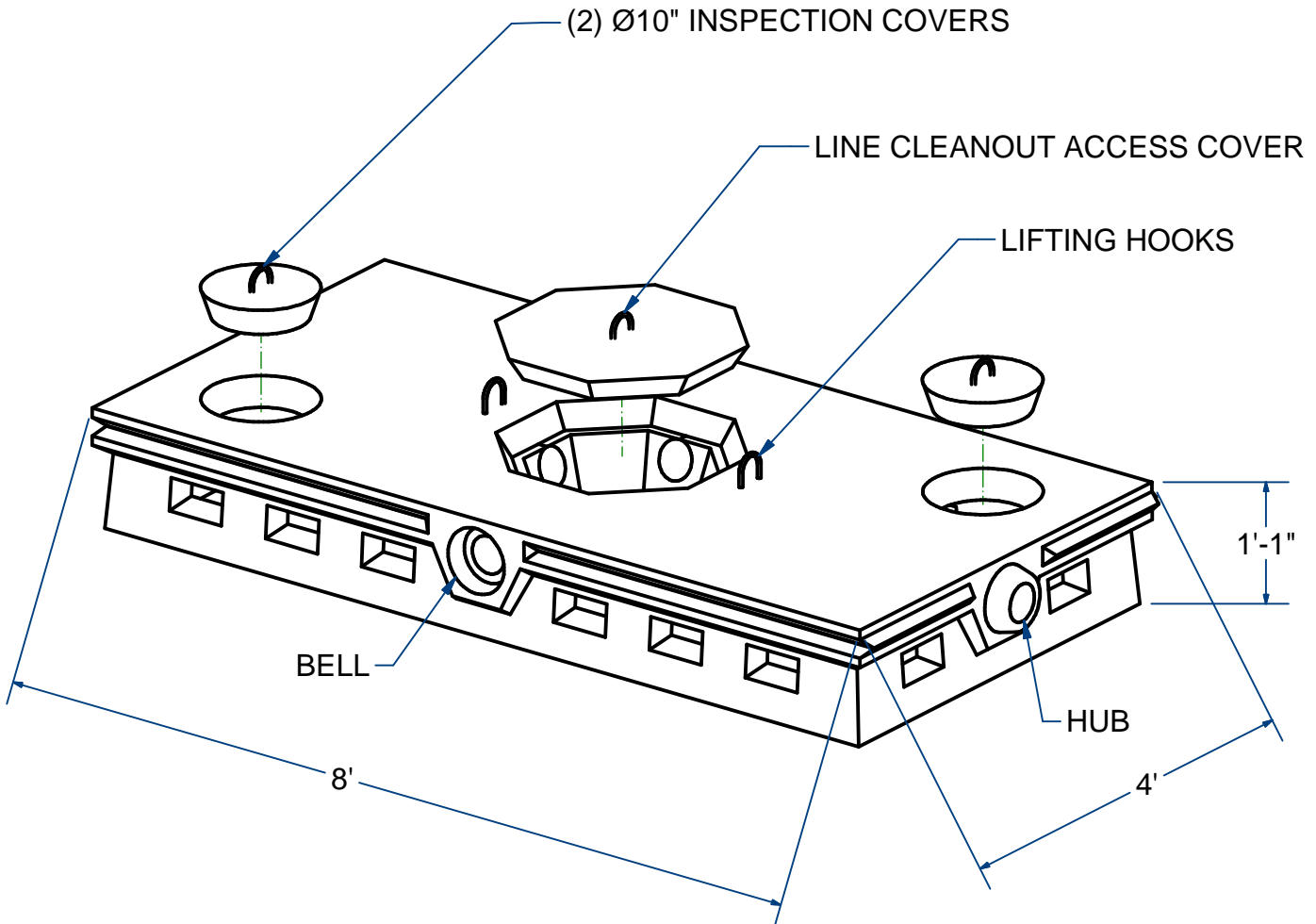

FLOW DIFFUSOR, LOW PROFILE

H20

'D' MODEL

ITEM# FDDL2

Wt. 2,100 Lbs

12-1.2

Sht 1 of 2

ACME-SHOREY

PRECAST CONCRETE PRODUCTS

NOTES:

- 1.) Ø4" CONCRETE HUB & BELL CONNECTORS ALLOW FOR P.V.C. PIPE AND ALSO FOR JOINING FLOW DIFFUSOR TO FLOW DIFFUSOR.

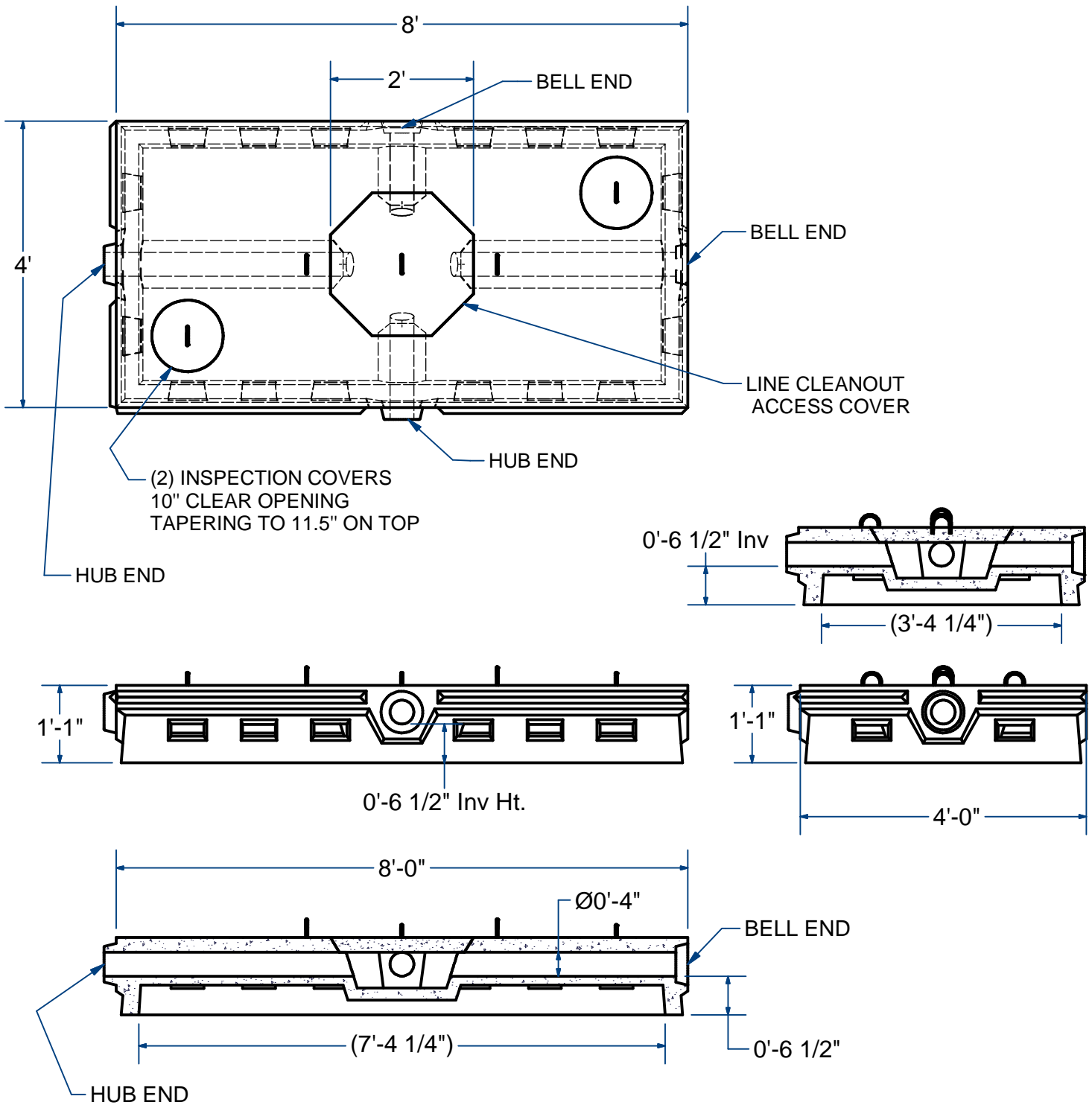

NAME: FLOW DIFFUSOR, LOW PRO, MODEL 'D' H-20

ITEM# FDDL P2

Concrete Minimum Strength: 5,000 p.s.i. at 28 days
Steel Reinforcement: ASTM A615, Grade 60
Design Loading: standard units - AASHTO - H20

WEIGHT 2,100 Lbs

C

DATE: 3-12-23

Ch 12 Pg 1.2 Sht 2 of 2