

ACME-SHOREY

PRECAST CONCRETE PRODUCTS

WWW.ACME-SHOREY.COM

PHONE (508) 548-9607

FAX (508) 548-1664

CARVER, MA

334 TREMONT STREET

HARWICH, MA

36 GREAT WESTERN ROAD

NOTES:

- 1.) PROVIDED UNSEALED.
- 2.) MODIFIED FAST UNIT.

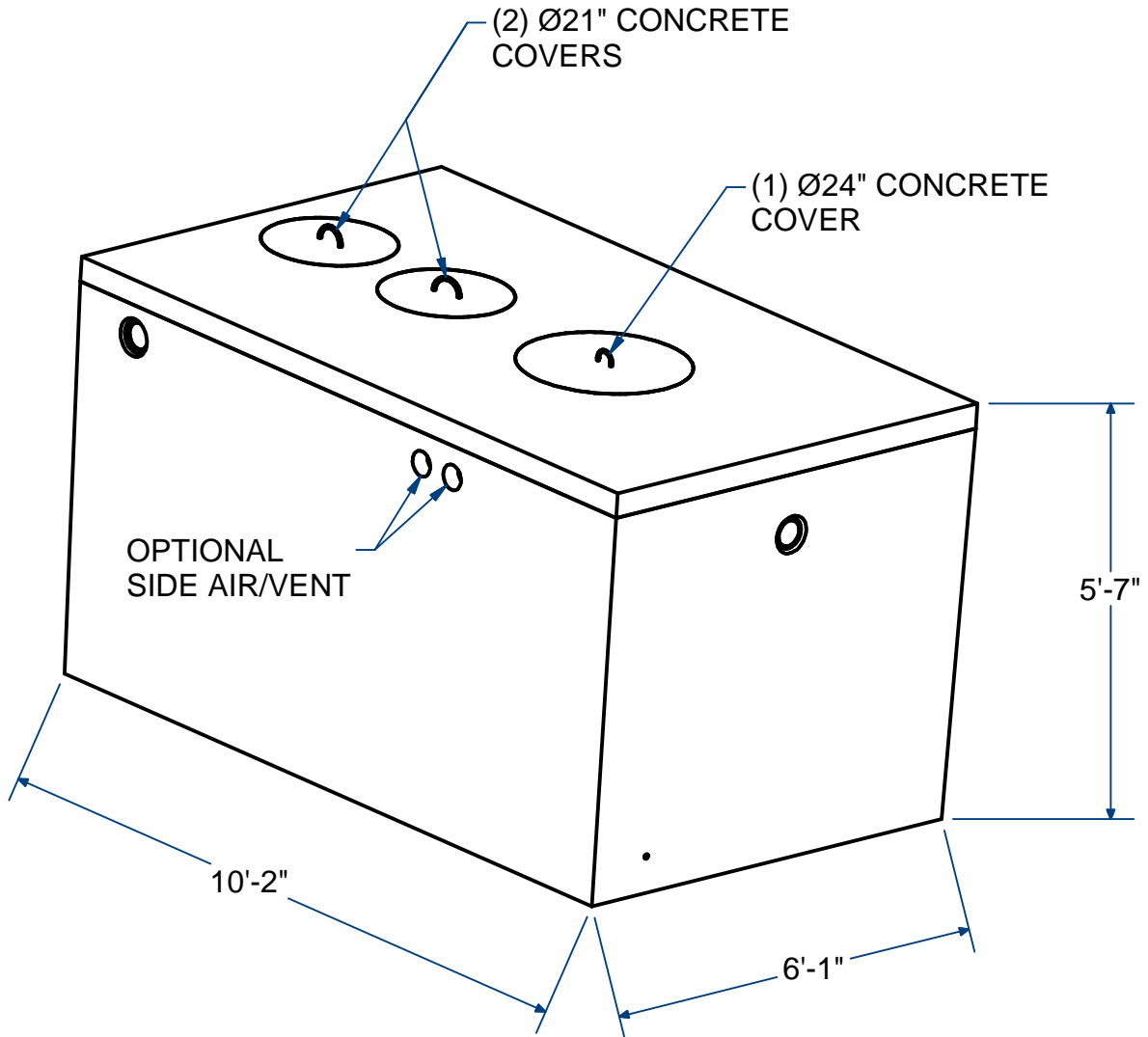

FAST TANK, INTERNAL MOUNT (MODELS 0.5,0.75,0.9, OR 1.0)

H10

1500 Gallon (LOW PROFILE)

ITEM# FTIM15MLPH

Wt. 14,000 Lbs

7 -5.1

Sht 1 of 2

ACME-SHOREY

PRECAST CONCRETE PRODUCTS

NOTES:

- 1.) UNSEALED (TO ALLOW FOR INSTALLATION OF FAST UNIT MODELS 0.5,0.75,0.9, OR 1.0)
- 2.) UNIT HEIGHT MODIFIED BY FAST.

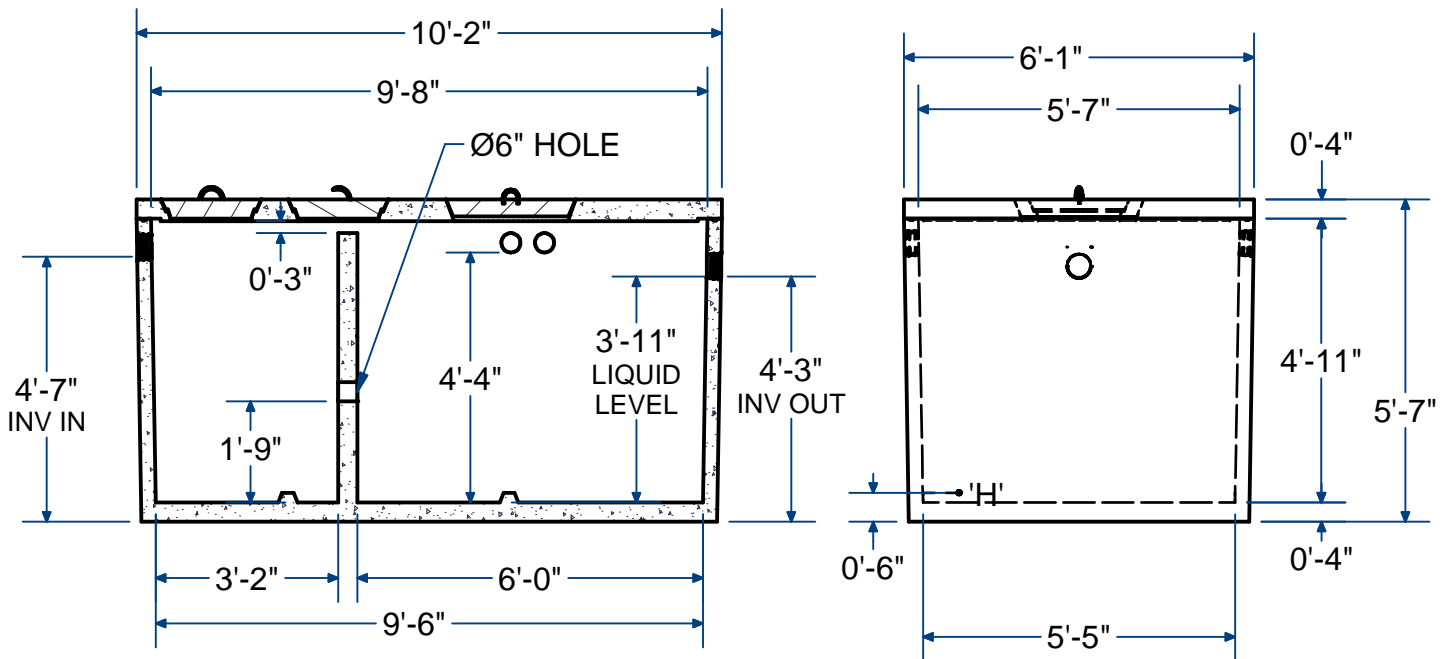
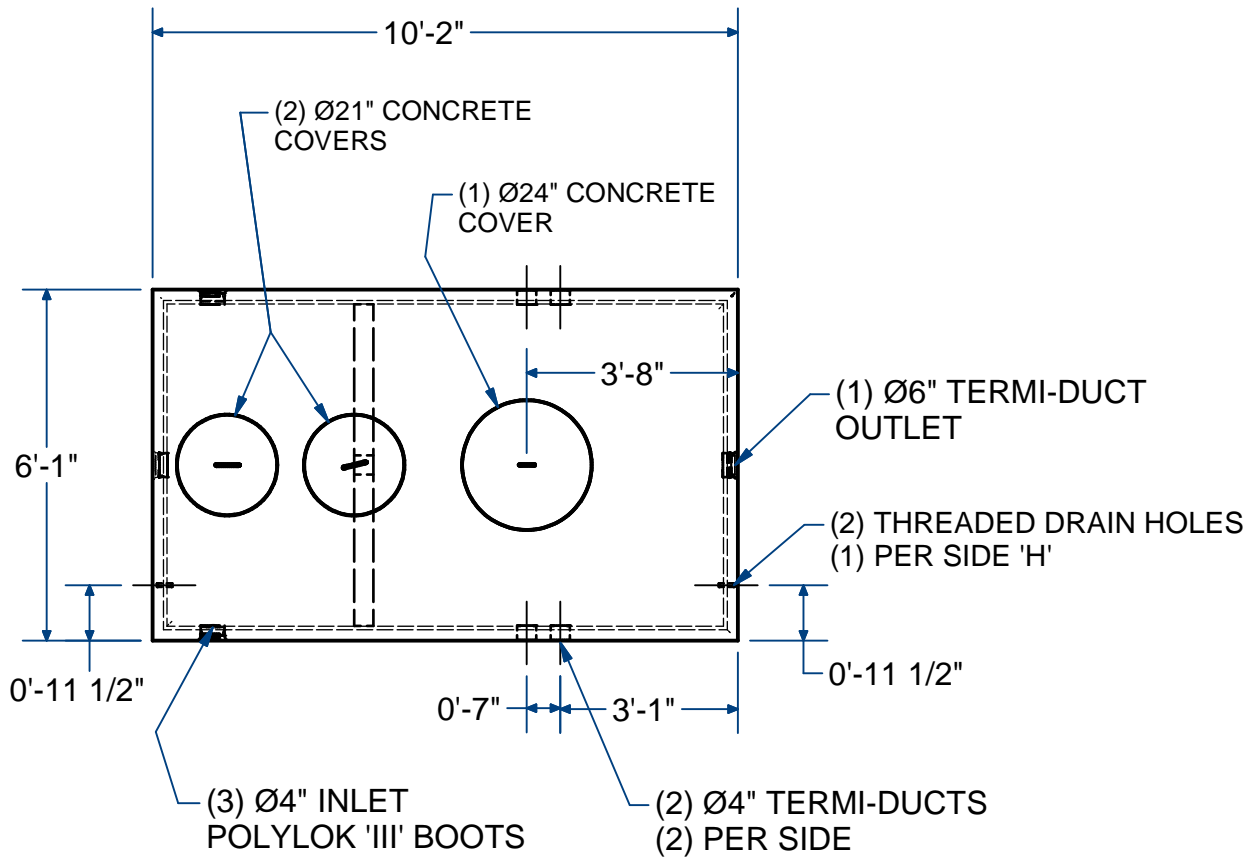

NAME: FAST TANK, INTERNAL MOUNT (.5,.75,.9,1.0)
(2-COMP, LOW PROFILE 1500 Gallon)

H-10

ITEM# FTIM15MLPH

Concrete Minimum Strength: 4,000 p.s.i. at 28 days
Steel Reinforcement: ASTM A615, Grade 60
Design Loading: standard units - AASHTO - H10

TOP 3,250 Lbs
BOTTOM 10,750 Lbs

H

DATE: 3-21-23

Ch 7 Pg 5.1 Sht 2 of 2