

ACME-SHOREY

PRECAST CONCRETE PRODUCTS

WWW.ACME-SHOREY.COM

PHONE (508) 548-9607

FAX (508) 548-1664

CARVER, MA
334 TREMONT STREET

HARWICH, MA
36 GREAT WESTERN ROAD

NOTES:

- 1.) SEAM SEALED WITH FLEXIBLE BUTYL RUBBER SEALANT.

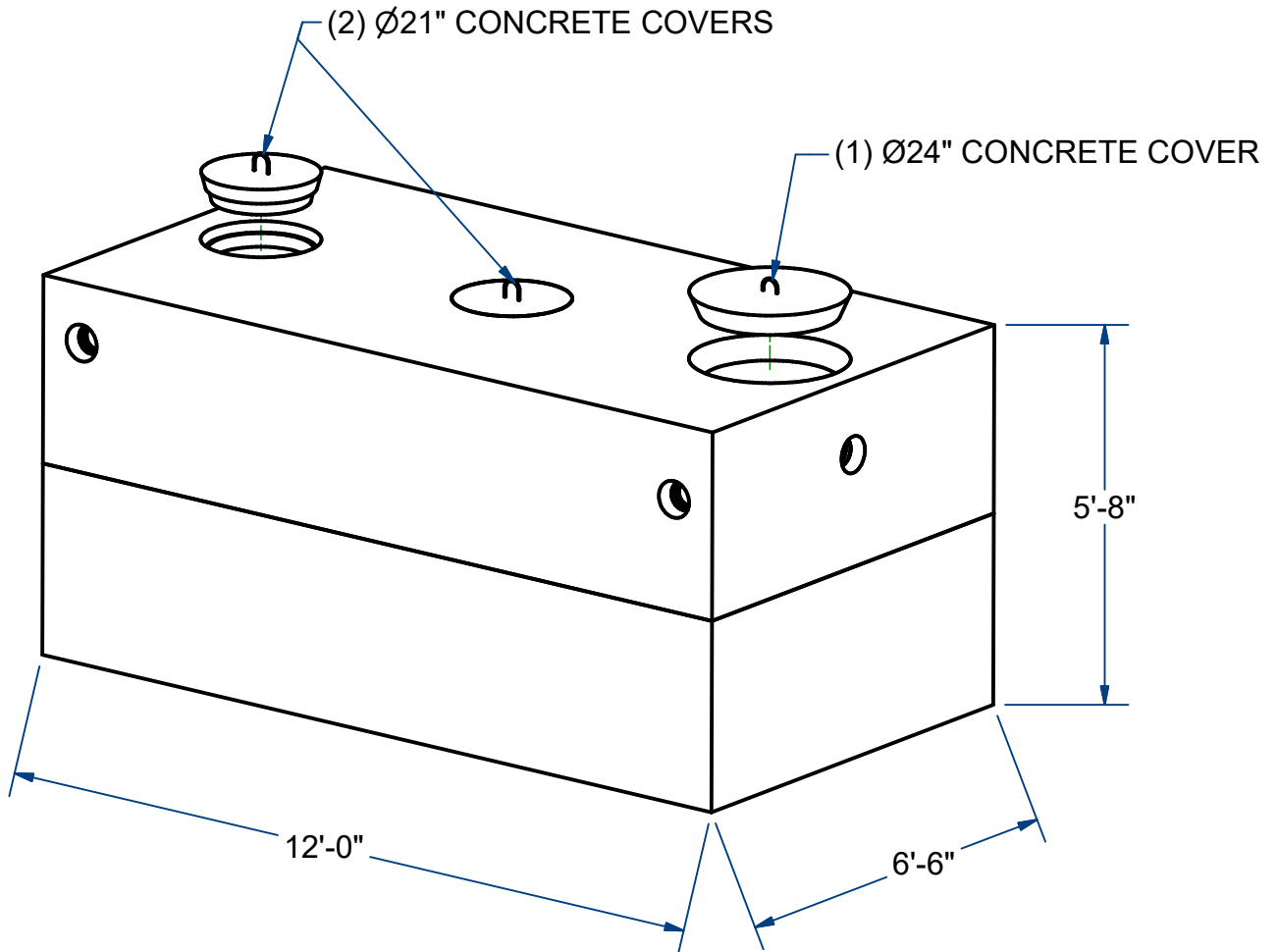

PUMP CHAMBER

H10

2000 Gallon

ITEM# PC20H

Wt. 18,000 Lbs

2 -6.1

Sht 1 of 2

ACME-SHOREY

PRECAST CONCRETE PRODUCTS

NOTES:

- 1.) SEAM SEALED WITH FLEXIBLE BUTYL RUBBER SEALANT.

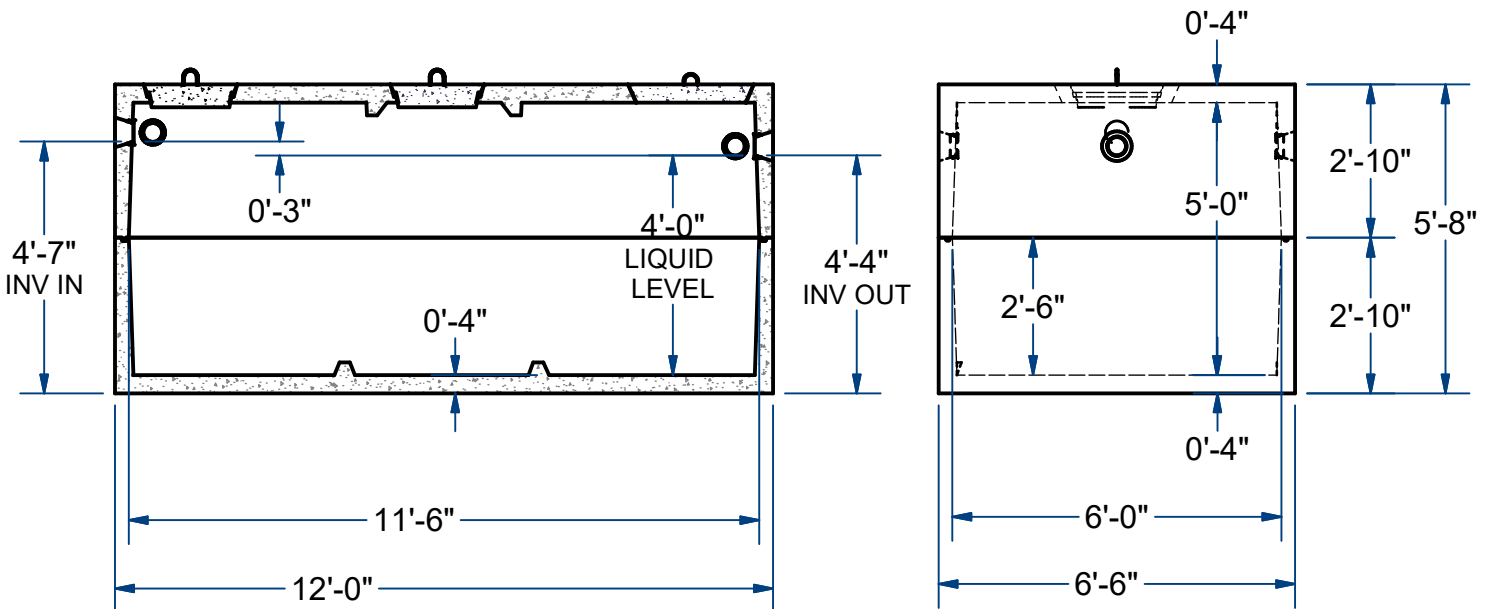
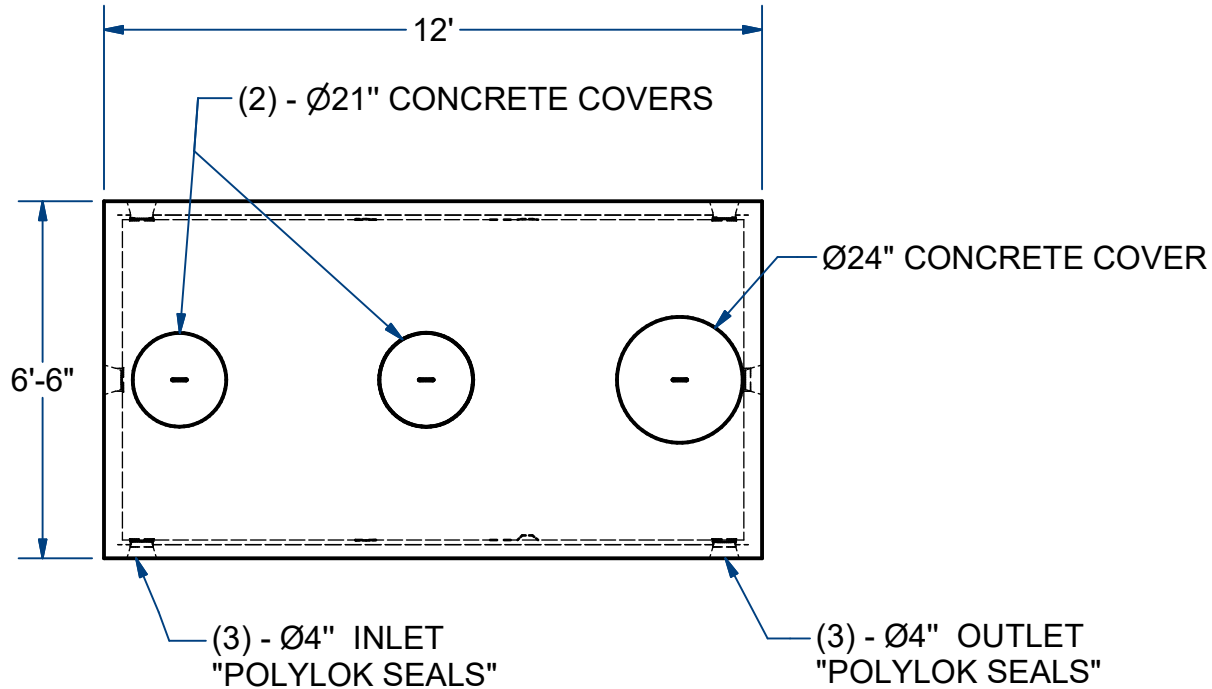

NAME: PUMP CHAMBER, 2,000 Gallon

H-10

ITEM# PC20H

Concrete Minimum Strength: 4,000 p.s.i. at 28 days
 Steel Reinforcement: ASTM A615, Grade 60
 Design Loading: standard units - AASHTO - H10

TOP 9,000 Lbs
 BOTTOM 9,000 Lbs

H

DATE: 1-20-26

Ch 2 Pg 6.1 Sht 2 of 2