

ACME-SHOREY

PRECAST CONCRETE PRODUCTS

WWW.ACMESHOREY.COM

PHONE (508) 548-9607

FAX (508) 548-1664

CARVER, MA

334 TREMONT STREET

HARWICH, MA

36 GREAT WESTERN ROAD

NOTES:

- 1.) Ø2" COUPLING MAY BE SLEEVED DOWN FOR ELECTRICAL CONDUIT.
- 2.) TYPICALLY USED FOR ELECTRICAL PUMPS OR ALARMS.

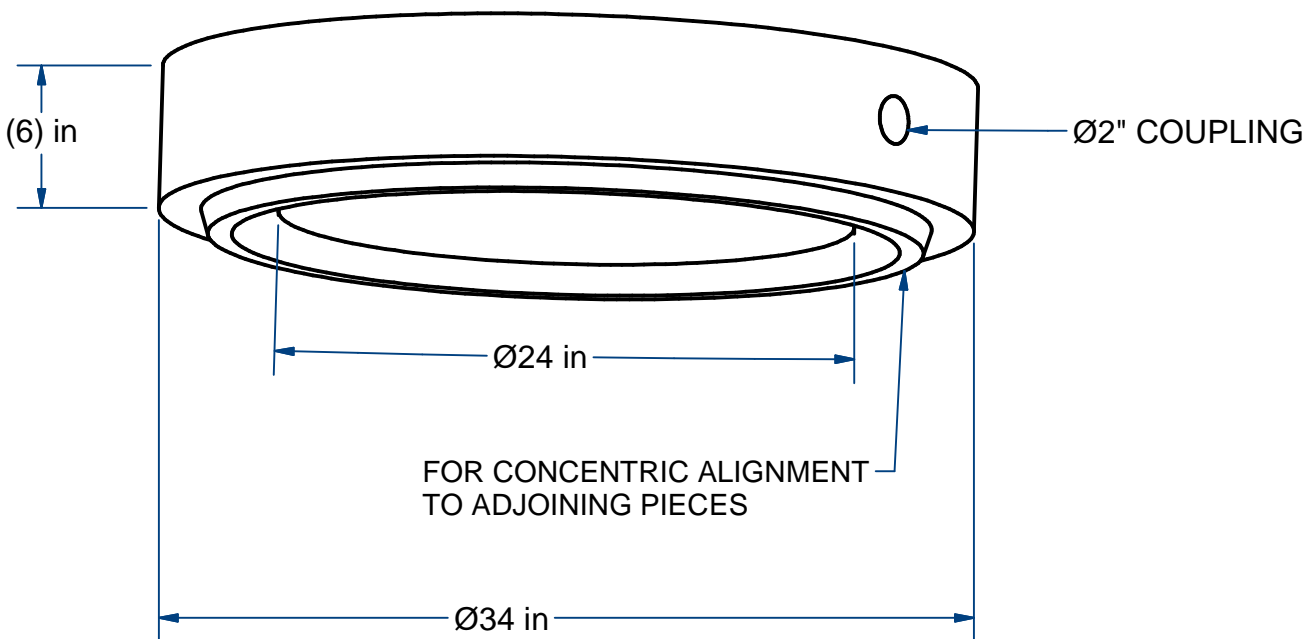

**RISER 24" ID
W/2" COUPLING**

H20

6" Ht.

ITEM# R24X06FH

Wt. 250

Lbs

13-5.1

Sht 1 of 2

ACME-SHOREY

PRECAST CONCRETE PRODUCTS

NOTES:

- 1.) Ø2" COUPLING MAY BE SLEEVED DOWN FOR ELECTRICAL CONDUIT.

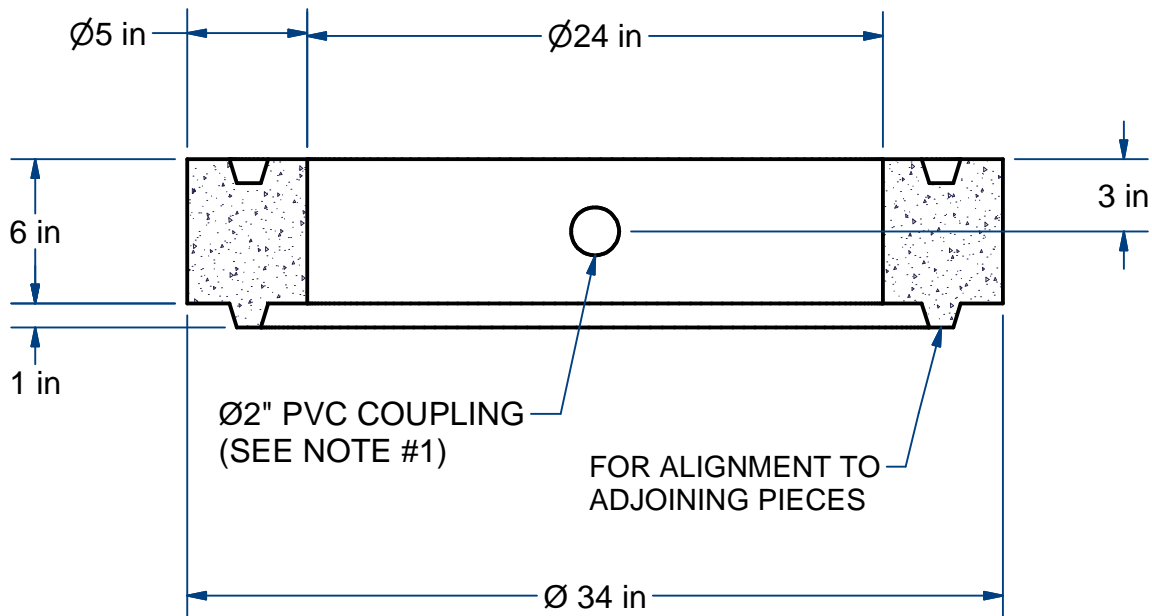
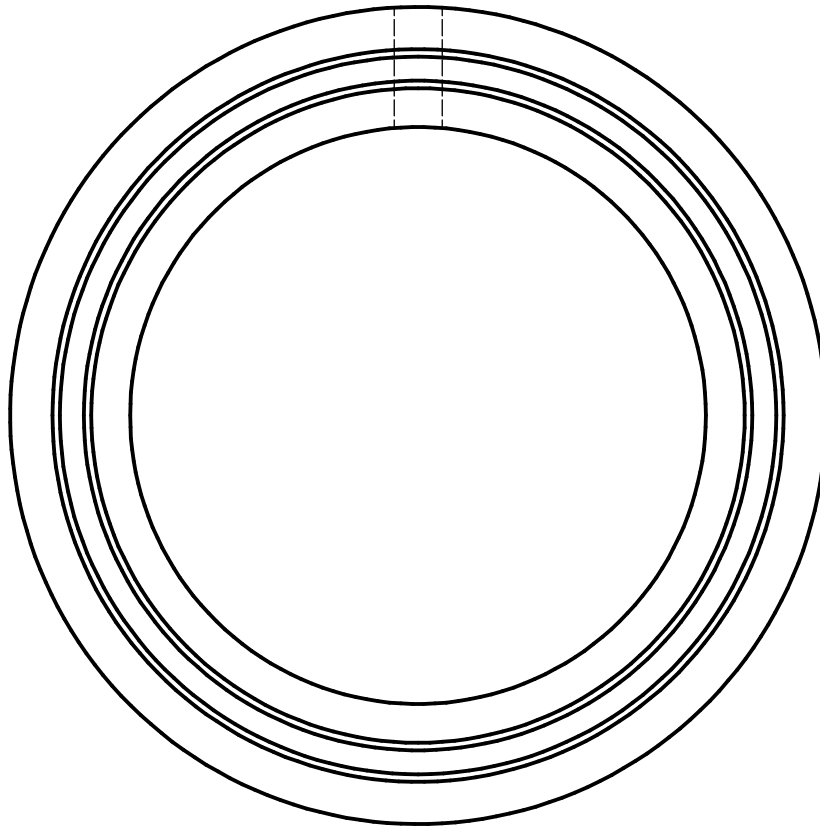

NAME: RISER 24"ID X 6"Ht, W/side Coupling

H-20

ITEM# R24X06FH

Concrete Minimum Strength: 5,000 p.s.i. at 28 days
 Steel Reinforcement: ASTM A615, Grade 60
 Design Loading: standard units - AASHTO - H20

WEIGHT 250

Lbs

C

DATE: 3-14-23

Ch 13 Pg 5.1 Sht 2 of 2