

NOTES:

- 1.) SEAM SEALED WITH FLEXIBLE BUTYL RUBBER SEALANT.

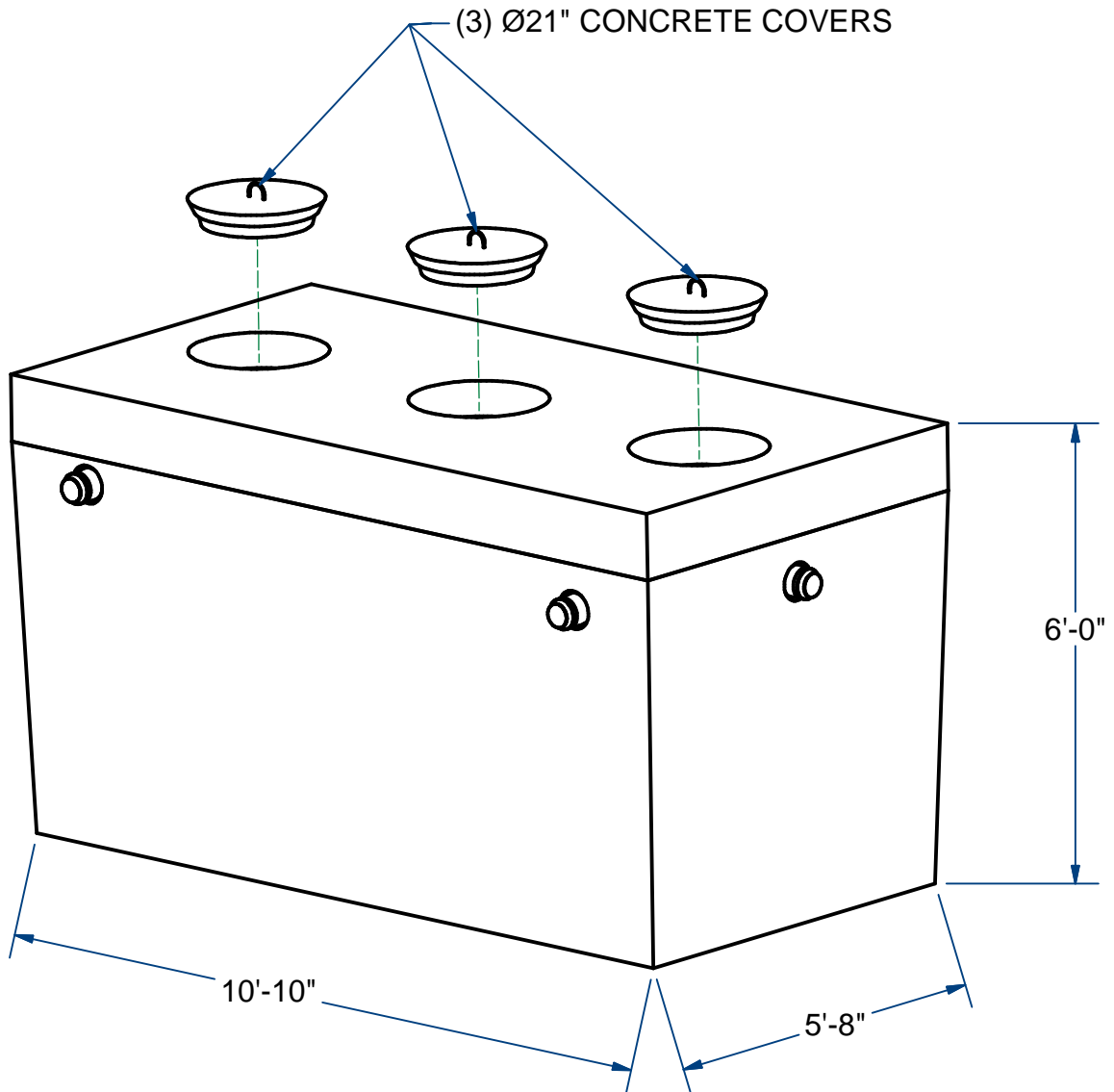

SEPTIC TANK MONOLITHIC HEAVY TOP

H10

1500 GALLON

ACME-SHOREY

PRECAST CONCRETE PRODUCTS

NOTES:

- 1.) SEAM SEALED WITH FLEXIBLE BUTYL RUBBER SEALANT.

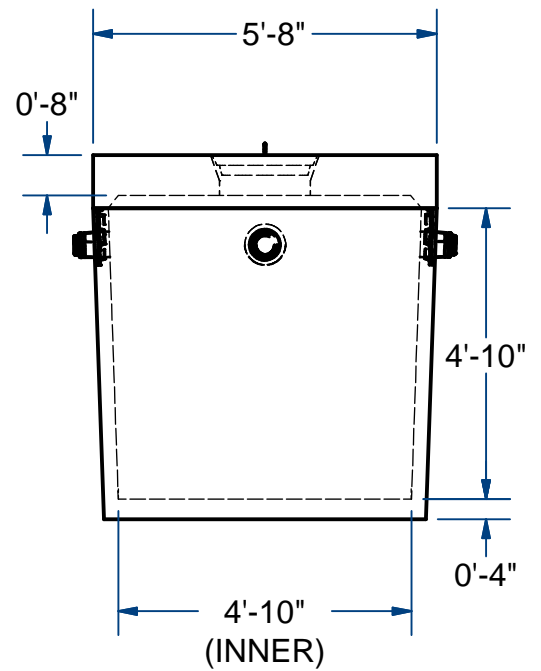
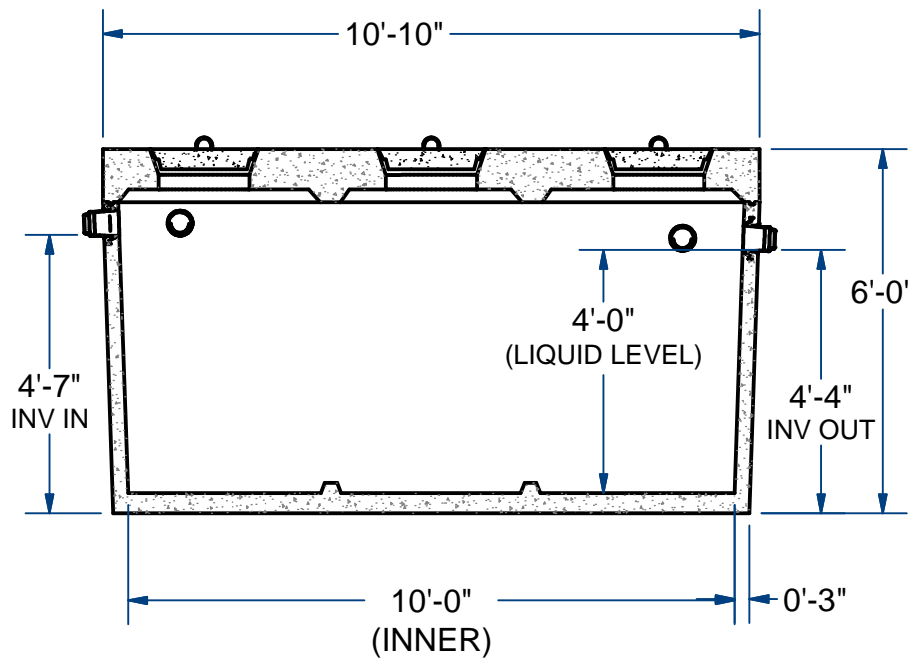
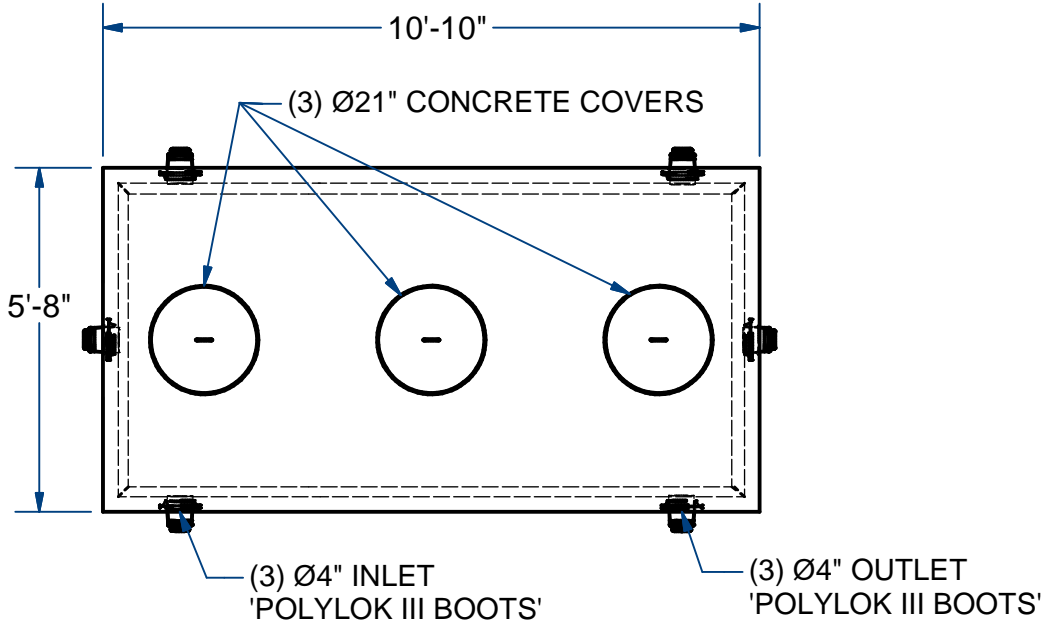

NAME: SEPTIC TANK, 1500G, Mono, HEAVY TOP H-10

ITEM# ST15MHT

Concrete Minimum Strength: 4,000 p.s.i. at 28 days
 Steel Reinforcement: ASTM A615, Grade 60
 Design Loading: standard units - AASHTO - H10

TOP 6,500 Lbs
 BOTTOM 8,500 Lbs

A

DATE: 7-24-2018