

ACME-SHOREY

PRECAST CONCRETE PRODUCTS

WWW.ACMESHOREY.COM

PHONE (508) 548-9607

FAX (508) 548-1664

CARVER, MA
334 TREMONT STREET

HARWICH, MA
36 GREAT WESTERN ROAD

NOTES:

- 1.) SEAM SEALED WITH FLEXIBLE BUTYL RUBBER SEALANT.
- 2.) COMPARTMENT VOLUME (1526 / 538 Gallons)

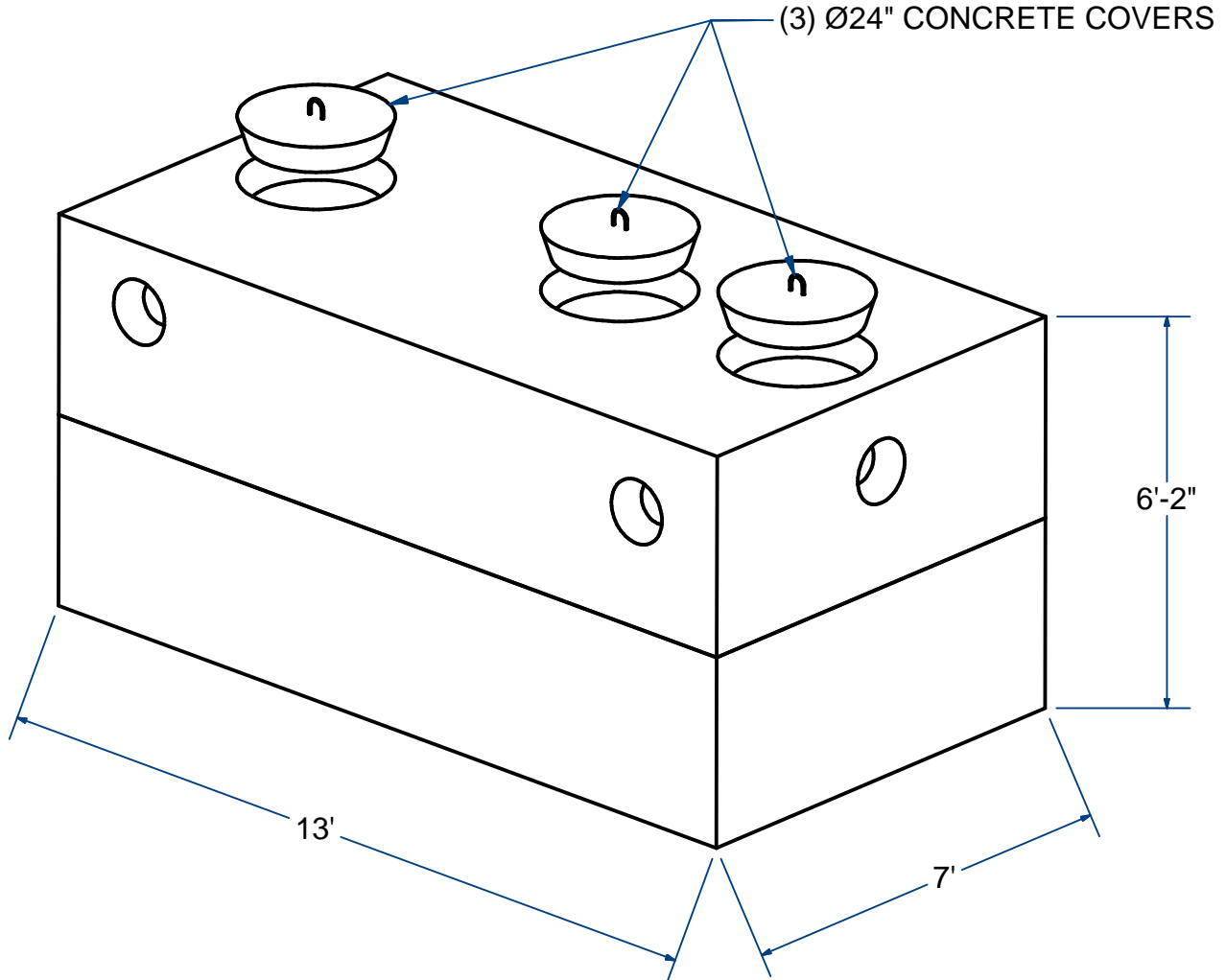

SEPTIC TANK PUMP CHAMBER LOW PROFILE

H20

2000 Gallon

ITEM# STPC202LP

Wt. 33,500 Lbs

10-3.1

Sht 1 of 2

ACME-SHOREY

PRECAST CONCRETE PRODUCTS

NOTES:

- 1.) SEAM SEALED WITH FLEXIBLE BUTYL RUBBER SEALANT.
- 2.) COMPARTMENT VOLUME (1526 / 538 Gallons)

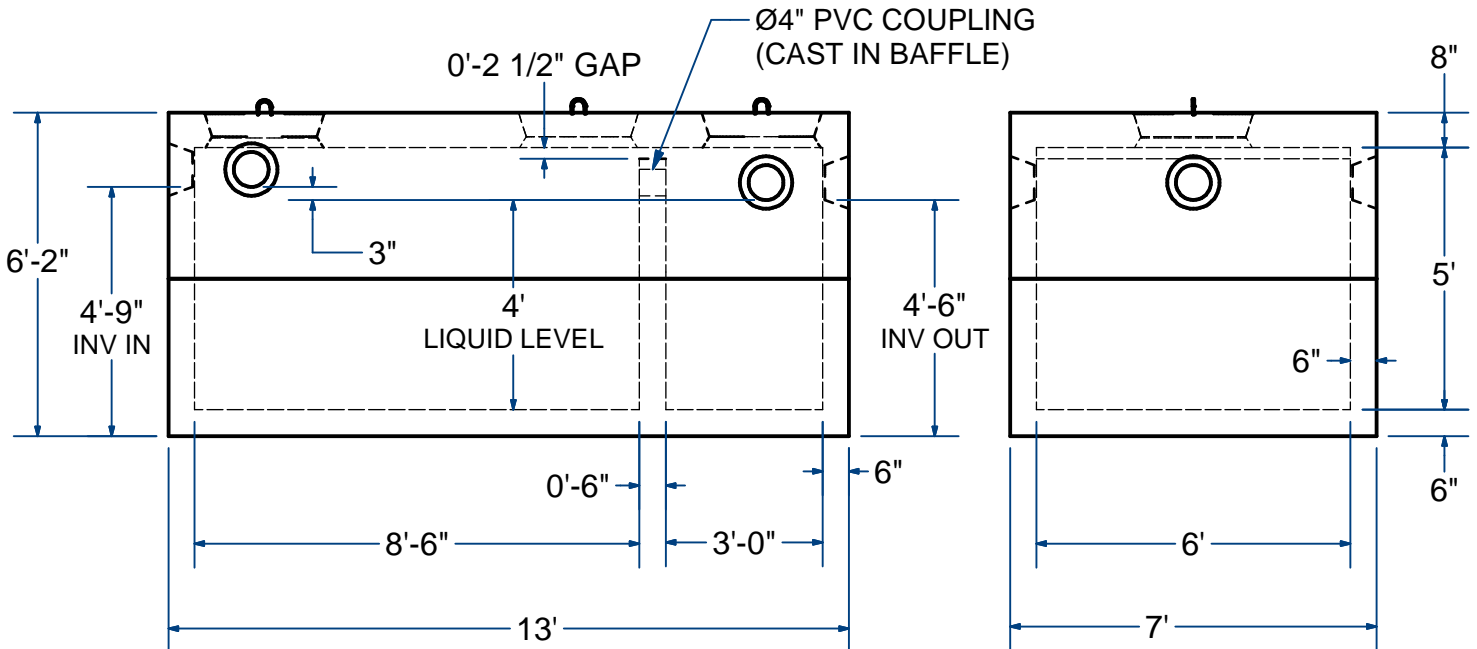
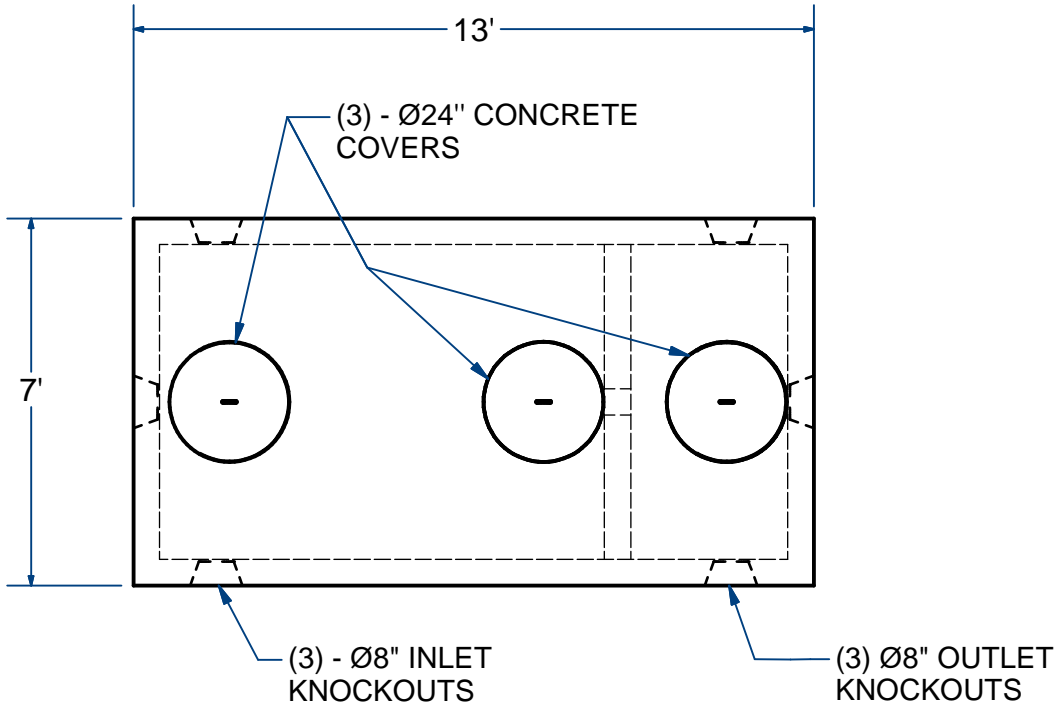

NAME: SEPTIC TANK-PUMP CHAMBER, 2000 Gallon H-20 ITEM# STPC202LP

Concrete Minimum Strength: 5,000 p.s.i. at 28 days
 Steel Reinforcement: ASTM A615, Grade 60
 Design Loading: standard units - AASHTO - H20

TOP 17,000 Lbs
 BOTTOM 16,500 Lbs

C DATE: 3-4-2019
 Ch 10 Pg 3.1 Sht 2 of 2