

# ACME-SHOREY

PRECAST CONCRETE PRODUCTS

WWW.ACMESHOREY.COM

PHONE (508) 548-9607

FAX (508) 548-1664

CARVER, MA  
334 TREMONT STREET

HARWICH, MA  
36 GREAT WESTERN ROAD

## NOTES:

- 1.) SEAM SEALED WITH FLEXIBLE BUTYL RUBBER SEALANT.

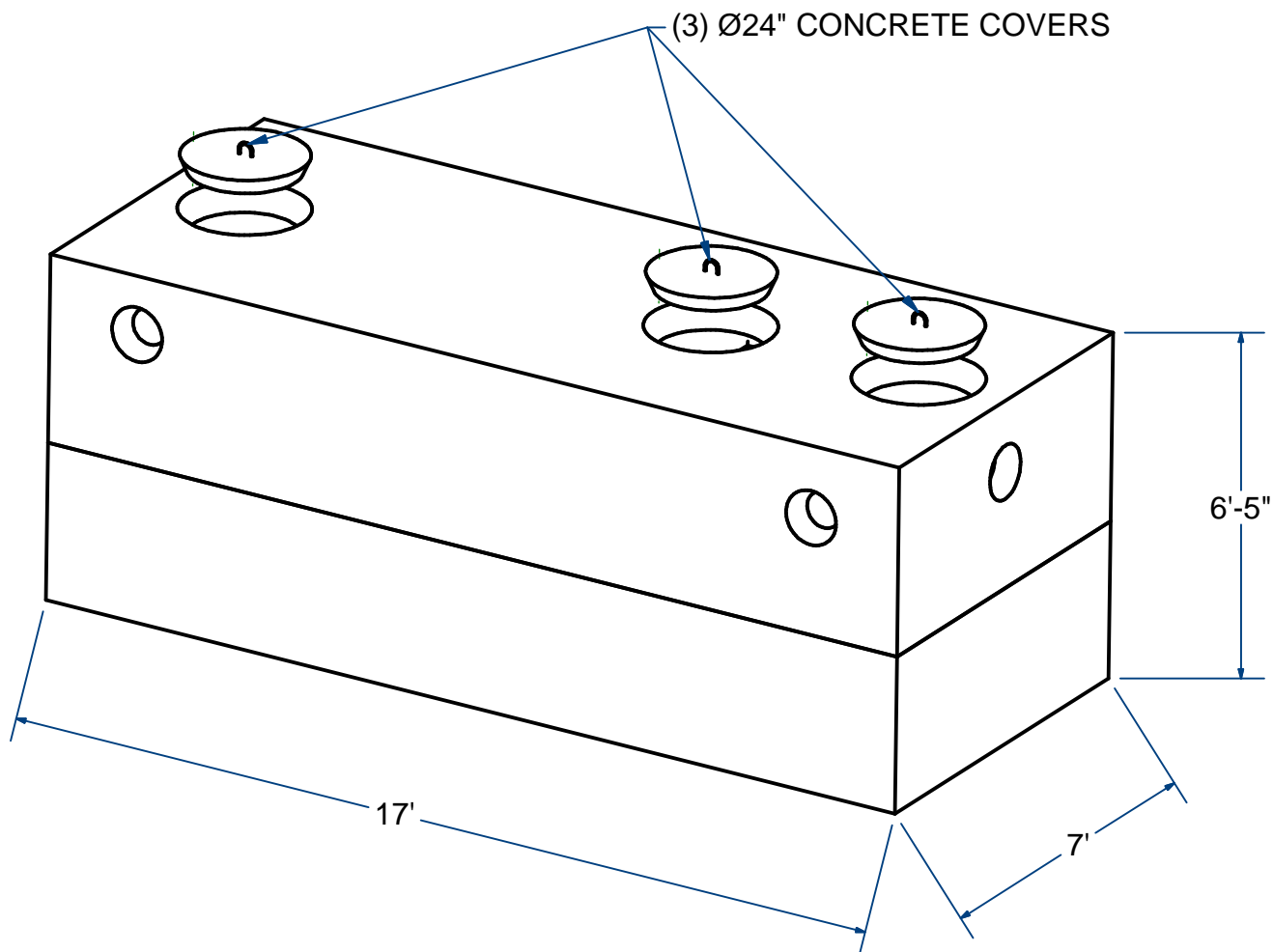

## 2-COMPARTMENT TANK, 7' X 17'

3,000 Gallon

H2O

ITEM# STPC730C

Wt. 40,500 Lbs

10-15.1

Sht 1 of 2

# ACME-SHOREY

PRECAST CONCRETE PRODUCTS

**NOTES:**

- 1.) SEAM SEALED WITH FLEXIBLE BUTYL RUBBER SEALANT.

Each	Size	Ht	wt.(Lbs)
Top	1000G	42"	22,000
Bottom	2000G	35"	18,500
			40500

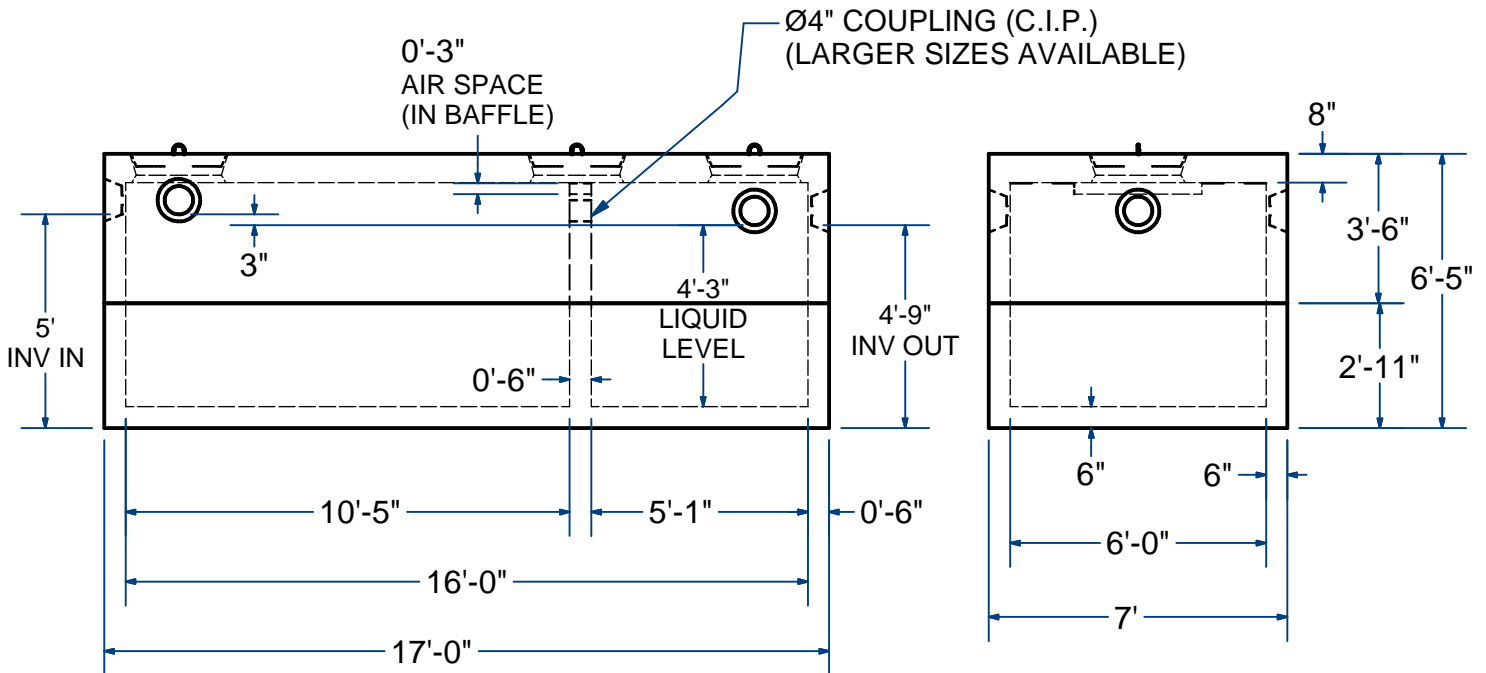
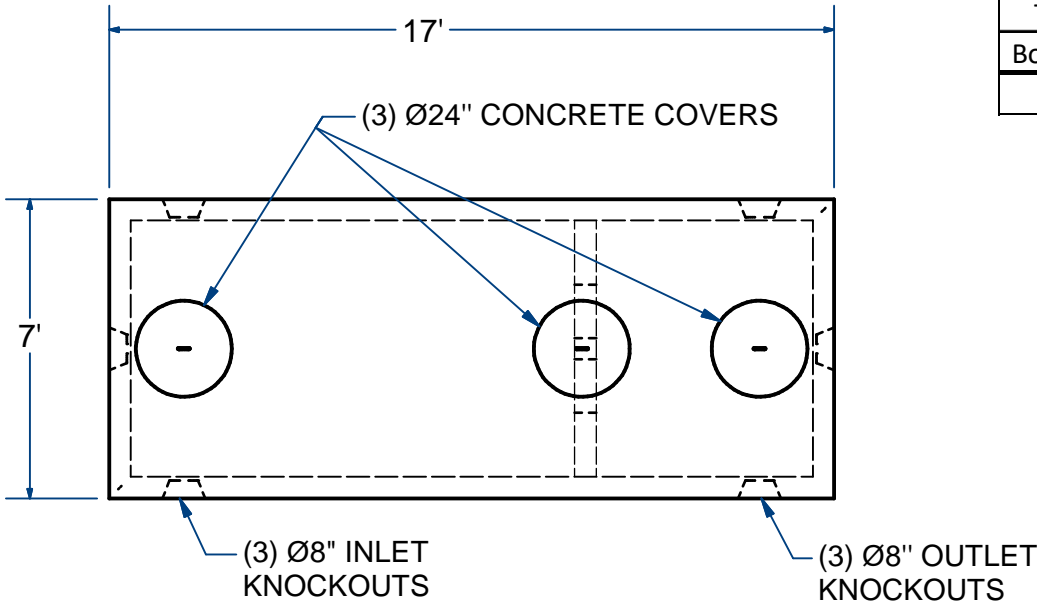

**NAME: 2-COMPARTMENT TANK 7'X17' , 3,000 Gallon H-20** **ITEM# STPC730C**

Concrete Minimum Strength: 5,000 p.s.i. at 28 days  
 Steel Reinforcement: ASTM A615, Grade 60  
 Design Loading: standard units - AASHTO - H20

WEIGHT 40,500 Lbs

C

DATE: 12-10-21

Ch 10 Pg 15.1 Sht 2 of 2