

ACME-SHOREY

PRECAST CONCRETE PRODUCTS

WWW.ACMESHOREY.COM

PHONE (508) 548-9607

FAX (508) 548-1664

CARVER, MA
334 TREMONT STREET

HARWICH, MA
36 GREAT WESTERN ROAD

NOTES:

- 1.) SEAM SEALED WITH FLEXIBLE BUTYL RUBBER SEALANT.

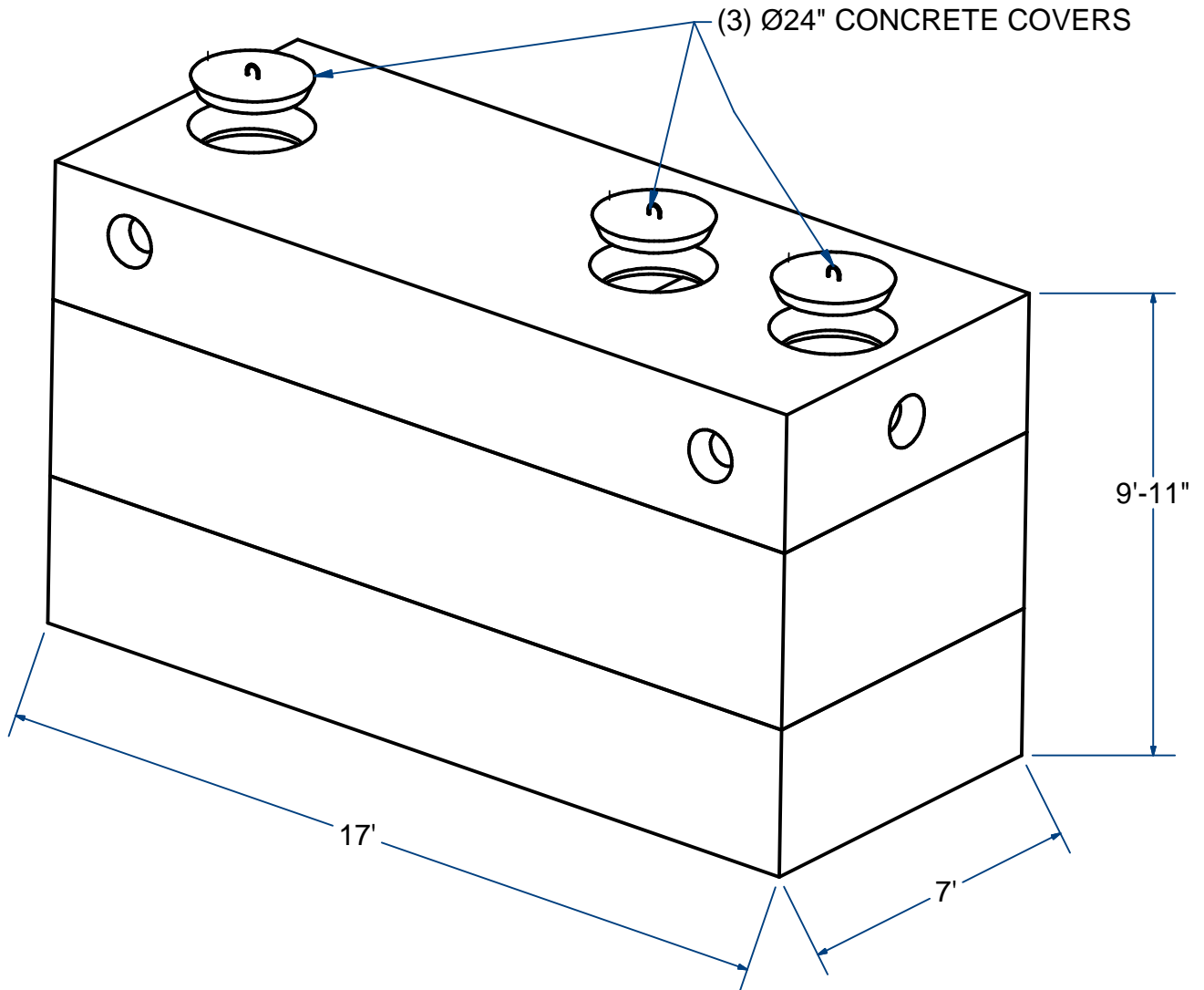

2-COMPARTMENT TANK

7' X 17'

5,500 Gallon

H2O

ITEM# STPC755C

Wt. 54,500 Lbs

10-15.6

Sht 1 of 2

ACME-SHOREY

PRECAST CONCRETE PRODUCTS

NOTES:

1.) SEAM SEALED WITH FLEXIBLE BUTYL RUBBER SEALANT.

Each	Size	Ht	wt.(Lbs)
Top	1000G	42"	22,000
Sleeve	2500G	42"	14,000
Bottom	2000G	35"	18,500
			54,500

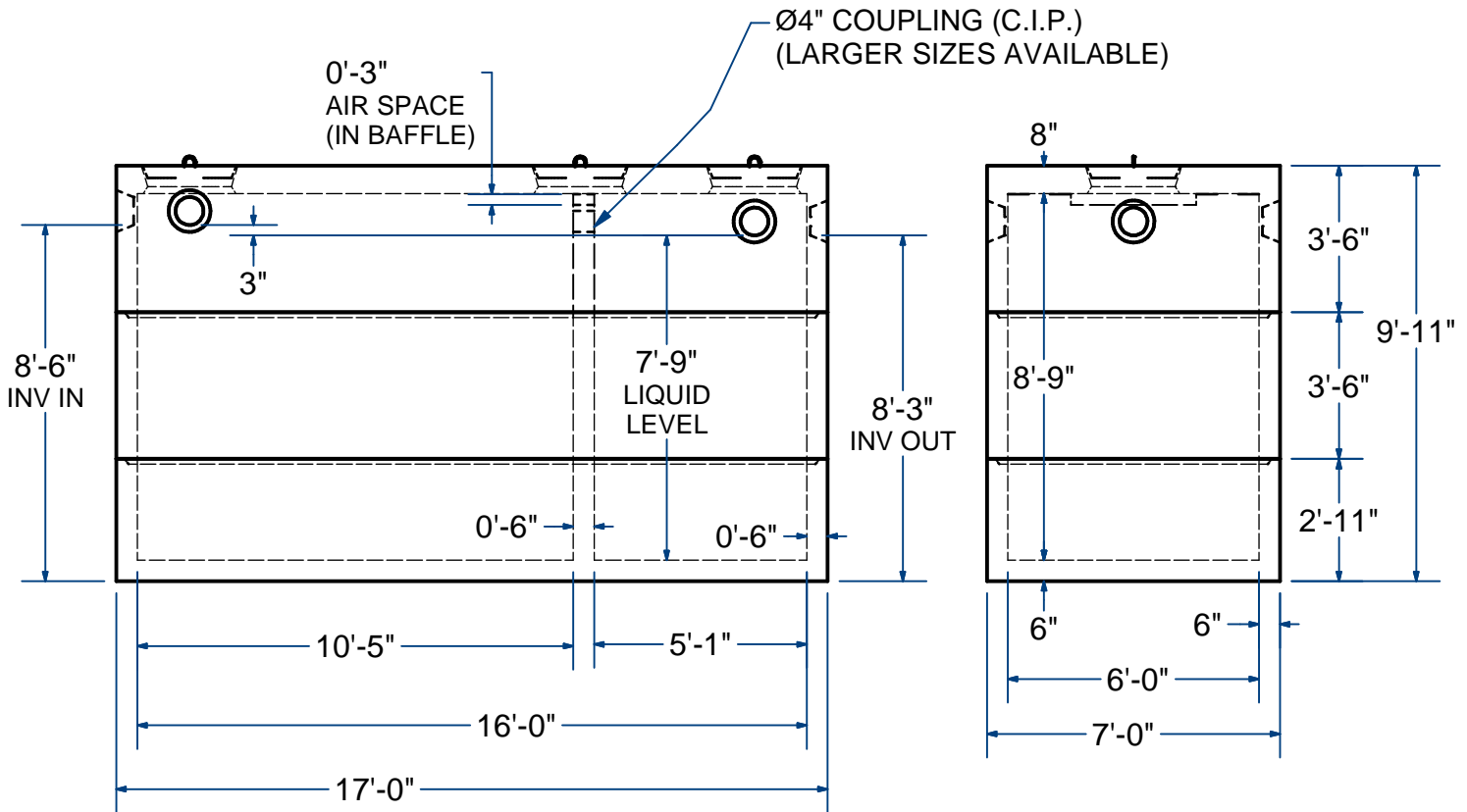
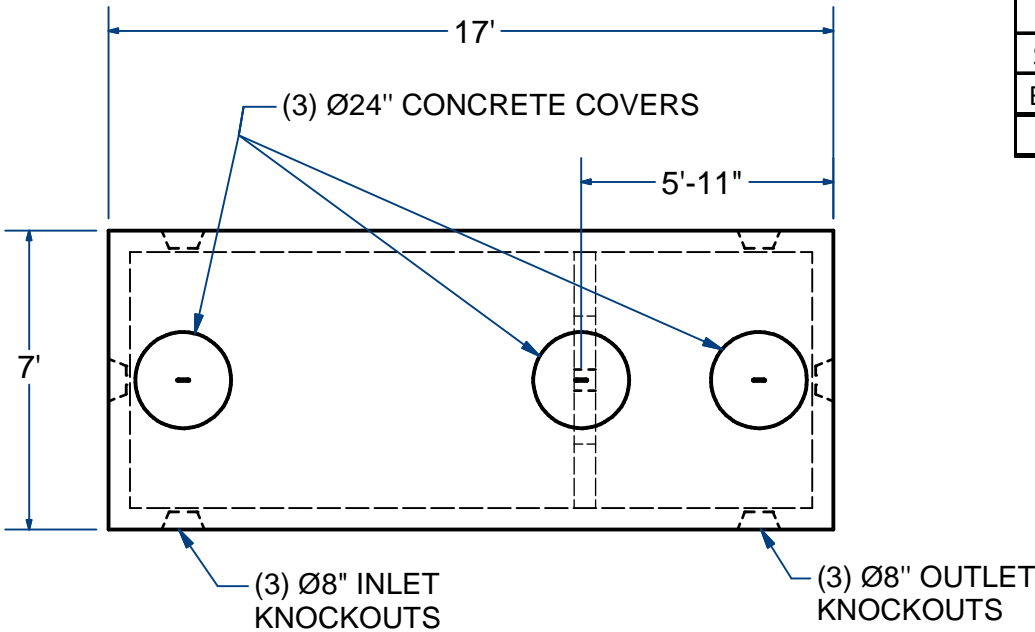

NAME: 2-COMPARTMENT TANK 7'X17', 5,500 Gallon H-20 ITEM# STPC755C

Concrete Minimum Strength: 5,000 p.s.i. at 28 days
 Steel Reinforcement: ASTM A615, Grade 60
 Design Loading: standard units - AASHTO - H20

WEIGHT 54,500 Lbs

C DATE: 12-13-21
 Ch 10 Pg 15.6 Sht 2 of 2